

Pump Stations DALP-C Series

Operating Instructions



Lit. Code
Manual No.

200007758-1-EN-GB
9019952 02 V.1

Component Description

Published by
Alfa Laval SpA
Product Development FCS & Modules
Via Pusiano 2
20900 Monza (MB), Italy

The original instructions are in English

© Alfa Laval Corporate AB 2022-09

This document and its contents are subject to copyrights and other intellectual property rights owned by Alfa Laval Corporate AB. No part of this document may be copied, re-produced or transmitted in any form or by any means, or for any purpose, without Alfa Laval Corporate AB's prior express written permission. Information and services provided in this document are made as a benefit and service to the user, and no representations or warranties are made about the accuracy or suitability of this information and these services for any purpose. All rights are reserved.

Contents

1	Warning signs in text	5
1.1	Warning signs	5
2	General information	7
2.1	General information	7
2.2	Target groups	7
2.3	Symbols.....	7
2.4	Associated documents	8
3	Safety	9
3.1	Proper use	9
3.2	Safety information	9
4	Labelling	11
4.1	Type code.....	11
4.2	Communication plate	12
5	Technical Data	13
5.1	Operating limits	13
5.1.1	Required NPSH values	14
5.1.2	Internal pressure loss of the pump station.....	15
5.2	Weights	16
5.2.1	Sound pressure levels	16
5.3	Dimensions.....	17
6	Functional description	19
6.1	Functional principle	20
6.1.1	Reversing valve	20
6.1.2	Pressure measurement.....	20
7	Transportation, Storage & Disposal	21
7.1	Unpacking and checking the state of delivery.....	21
7.1.1	Lifting the pump station	21
7.1.2	Storage	22
7.2	Preservation.....	22
7.2.1	Preserving the internal surfaces of the station	22
7.2.2	Preserving the external surfaces of the station.....	23
7.2.3	Removing the preservation	23
7.3	Disposing of the station.....	24
8	Installation, Removal & Connection	25

8.1	Installation.....	25
8.1.1	Installing the station	25
8.1.2	Protect the station against contamination	26
8.1.3	Connecting the station to the pipe system.....	27
8.2	Removal	28
9	Operation.....	29
9.1	Commissioning.....	29
9.1.1	Cleaning the pipe system.....	29
9.1.2	Filling and venting the station	30
9.1.3	Filling the station via the suction or pressure connection	31
9.1.4	Commissioning the station.....	32
9.2	During operation	33
9.2.1	Activating the reversing valve.....	33
9.2.2	Possible positions of the reversing valve.....	33
9.2.3	Reading the pressure values.....	34
9.3	Taking the station out of operation.....	36
10	Maintenance	39
10.1	Safety instructions on maintenance and repairs.....	39
10.1.1	Required maintenance	40
10.2	Replacing pump.....	41
11	Troubleshooting	43
11.1	Possible faults.....	43
11.2	Troubleshooting.....	43
12	Spare part kits	47
12.1	Maintenance kit - Station, without strainer.....	48
12.2	Molded gasket kit.....	49
12.3	Non-return valve kit.....	50
13	Appendix.....	51
13.1	General drawing	51
13.2	Tightening torques	52

1 Warning signs in text

1.1 Warning signs

Pay attention to the safety instructions in this manual. Below are definitions of the three grades of warning signs used in the text where there is a risk for injury to personnel.



Immediate threat of danger. Serious personal injury, death.



Possible threat of danger. Serious personal injury, invalidity.



Potentially dangerous situation. Slight personal injury. Material damage.



Note indicates a potentially hazardous situation which, if not avoided, may result in property damage.

2 General information

2.1 General information







The operating instructions form part of the pump station and must be kept for future reference.

Furthermore please observe the associated documents.

2.2 Target groups

Target group	Tasks
Operator-owner	<ul style="list-style-type: none"> • Keep these instructions available at the system site for future reference. • Ensure that employees read and observe these instructions and the associated documents, in particular the safety instructions and warnings. • Observe additional system-specific directives and regulations.
Specialist personnel, fitters	<ul style="list-style-type: none"> • Read, observe and follow these instructions and the associated documents, in particular the safety instructions and warnings.

2.3 Symbols

Symbol	Meaning
	Warning personal injury.
	Notice.
	Procedures mechanical installation.
	Procedures electrical installation.
	Check or fault table.
	Request for action.

2.4 Associated documents

- Pump operating instructions
- ATEX supplementary instructions for operation in potentially explosive areas.
- Declaration of Conformity according to EU Directive 2006/42/EC.
- Declaration of Conformity according to EU Directive 94/9/EC.
- Manufacturer's declaration as per EU Directive 97/23/EC.
- Technical documentation for supplied components.

3 Safety

3.1 Proper use

Use the pump station only for transporting lubricating liquids that are chemically neutral and that contain no gas or solid components.

Use the pump station only within the performance limitations specified on the communication plate and in the “Technical data” section. In the case of operating data that does not agree with the specifications on the communication plate, please contact the manufacturer.

The pump station is specifically configured for the operating pressure stated by the customer. In the case of a significant difference between actual and configured operating pressure damages can occur even within the stated performance limitations. This applies both to notably higher as well as to notably lower operating pressures. In case of any doubt, please contact the manufacturer.

3.2 Safety information

NOTE

The following general safety instructions must be observed.

- No liability is accepted for damage arising through non-observance of the operating instructions.
 - Read the operating instructions carefully and observe them.
 - The operator-owner is responsible for the observance of the operating instructions.
 - Installation, removal and installation work may only be carried out by specialist personnel.
- In order for the warranty to remain valid, corrective maintenance carried out during the warranty period requires the express permission of the manufacturer.
- Observe the general regulations for the prevention of accidents as well as the local safety and operating instructions.
- Observe the valid national and international standards and specifications of the installation location.
- In case of systems with an increased potential of danger to humans and/or machines the failure of a pump may not lead to injuries or damage to property.
- Always equip systems with an increased potential of danger with alarm equipment.
- Maintain and check the protective/alarm equipment regularly.
- The pumped liquids can be dangerous (e.g. hot, dangerous to health, poisonous, combustible). Observe the safety regulations for handling dangerous materials.
- Pumped liquid can be subject to high pressure and can cause damage and/or personal injury should leaks occur.





Safety

4 Labelling

4.1 Type code

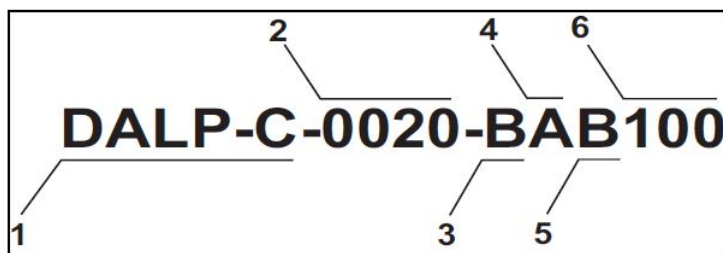

1. Model
2. Size
3. Shaft seal
4. Overflow valve
5. Completion
6. Motor size

Figure 1: Type code

Table 1: Type code

Pos.	Designation	Type	
1	Model	DALP-C	Double station supply.
2	Size	Corresponds to flow rate in [l/min] at 1 450 min ⁻¹	
3	Shaft seal	B	Mechanical seal of hard material.
		D	Magnetic coupling. Up to April 2022.
		M	Magnetic coupling. From May 2022.
4	Overflow valve		Opening at differential pressure [bar].
		A	6 ± 10 %
		B	10 ± 10 %
5	Completion	A	Pump with free shaft end.
		B	Pump unit for vertical mounting, with pump bracket and coupling.
		C	Pump unit for horizontal mounting, with pump bracket, pump bracket foot and coupling.
		D	Pump unit for vertical mounting, with pump bracket, coupling and motor.
		E	Pump unit for horizontal mounting, with pump bracket, pump bracket foot, coupling and motor.
6	Motor size	80	
		90	
		100	
		112	
		132	

4.2 Communication plate

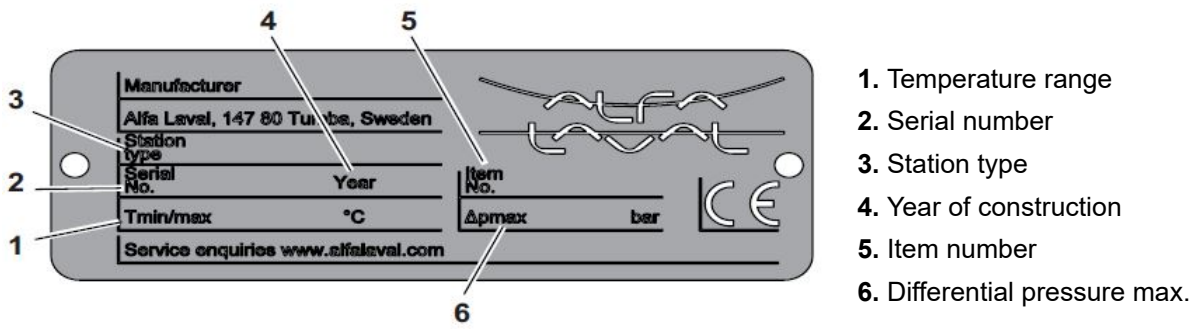

1. Temperature range
2. Serial number
3. Station type
4. Year of construction
5. Item number
6. Differential pressure max.

Figure 2: Communication plate

5 Technical Data

5.1 Operating limits

Table 2: Operating limits

	DALP-C	
	Overflow valve A	Overflow valve B
Differential pressure max. [bar]	4	8
End pressure max. [bar]	16	16
Valve opening pressure [bar]	6 ± 10 %	10 ± 10 %
Temperature max. [°C]	155	155
Temperature min. [°C] for pump materials	-10	-10
Viscosity min. - max. [mm ² /s]	1.4 - 10000	1.4 - 10000
Rotation speed [min ⁻¹]		
@ 50 Hz	2900	2900
@ 60 Hz	3500	3500

5.1.1 Required NPSH values

The following table lists the required NPSH values during operation with a low-volatile liquid such as lubricating oil or hydraulic liquid. When liquids have a readily volatile component content, the required NPSH values increase notably:

- When the pumped liquid contains water (e. g. heavy fuel oil), the values in the table have to be increased by the vapor pressure of the water at the specified operating temperature.

The required NPSH values also need to be increased if there are gas contents, regardless of whether it is dissolved or not. In case of any doubt, please contact the manufacturer.

Table 3: Required NPSH values

Size	Viscosity [mm ² /s]	NPSH value [mWC] at Rotation speed [min ⁻¹]				Size	Viscosity [mm ² /s]	NPSH value [mWC] at Rotation speed [min ⁻¹]			
		1450	1750	2900	3500			1450	1750	2900	3500
ALP 15	6	2.0				ALP 55	6	2.0			
	37	2.0					37	2.0			2.7
	152	2.0			2.2		152	2.1		2.8	3.3
	380	2.0		2.7	3.0		380	2.5	2.7	3.5	4.0
ALP 20	6	2.0				ALP 75	6	2.0		2.6	3.0
	37	2.0					37	2.0		2.9	3.4
	152	2.0		2.4	2.7		152	2.3	2.5	3.3	4.1
	380	2.2	2.4	3.2	3.8		380	2.7	3.0	4.4	5.0
ALP 30	6	2.0				ALP 85	6	2.0		2.8	3.4
	37	2.0					37	2.0		3.1	3.8
	152	2.0		2.3	2.6		152	2.4	2.6	3.8	4.6
	380	2.2	2.4	3.1	3.7		380	2.8	3.1	4.6	5.8
ALP 40	6	2.0			2.3						
	37	2.0		2.1	2.6						
	152	2.0		2.8	3.5						
	380	2.5	2.7	4.0	4.8						

5.1.2 Internal pressure loss of the pump station

When determining the NPSH value of the pump station also take into account the internal pressure losses in the ducts of the station, in the reversing valve and particular in the strainer. The following diagram shows as an example the overall pressure loss from the suction connection of the station up to the suction flange of the pump at operation.

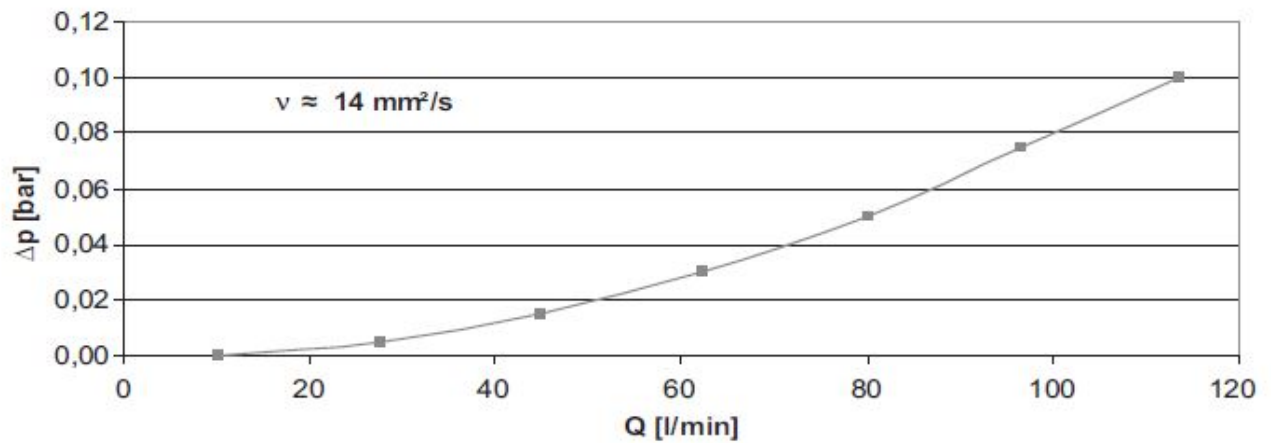

Δp Pressure loss

Q Delivery rate

5.2 Weights

Table 4: DALP-C weights

Part	
Station block with reversing valve	41.0 kg
Pump with coupling and motor	See corresponding pump operating instructions.
Filling volume of the station block	1.5 l

5.2.1 Sound pressure levels

Guide values at 1 m distance, 1450 min⁻¹, 20 bar, 21 mm²/s

Table 5: Sound pressure levels

Size	Sound pressure level max. ± 3[dB(aA)]		
	15 - 20	30 - 40	55 - 80
1 pump	56	59	65
2 pumps	59	62	68

5.3 Dimensions

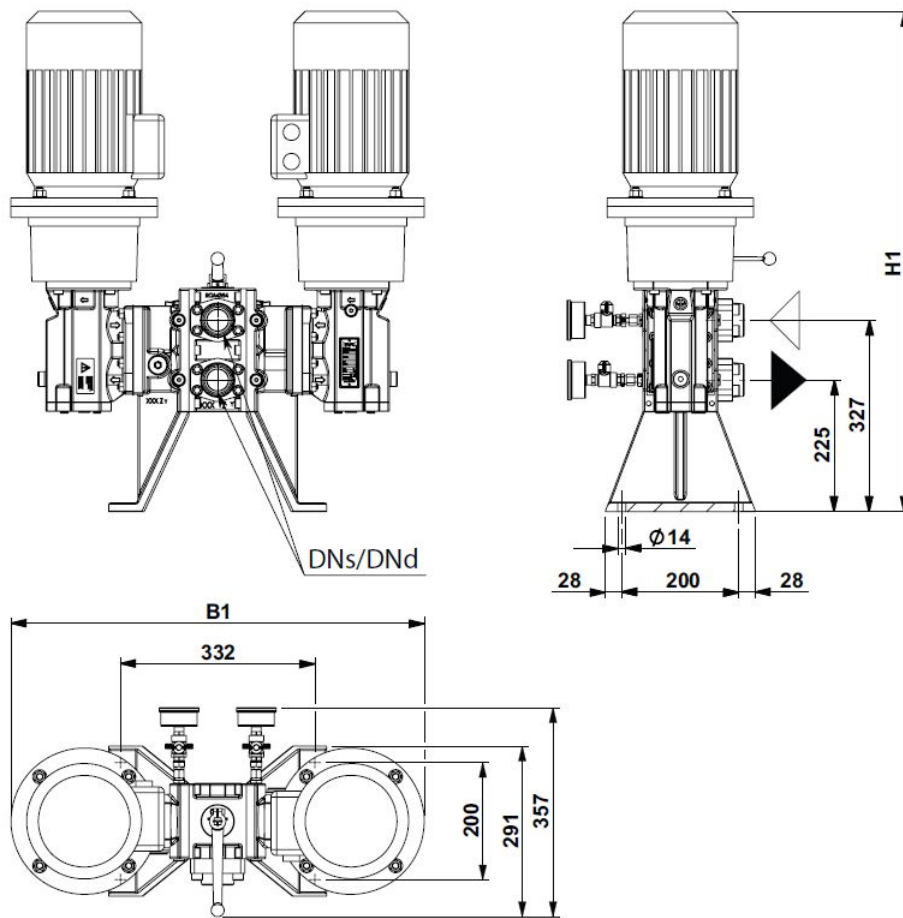

Figure 3: Dimensional drawing of DALP-C pump station

Table 6: Dimensions DALP-C pump station

Station Size	Pump size	Motor size	B1	H1	DNs/DNd
DALP-S	ALP		[mm]	[mm]	
0015 - 0020	15 - 20	80	636	739	SAE 1 1/2" 3000 PSI
		90	636	799	
		100	686	847	
		112	686	896	
0030 - 0040	30 - 40	80	636	745	
		90	636	805	
		100	686	853	
		112	686	902	
0050 - 0085	55 - 85	90	656	809	
		100	706	857	
		112	706	906	
		132	756	972	

6 Functional description

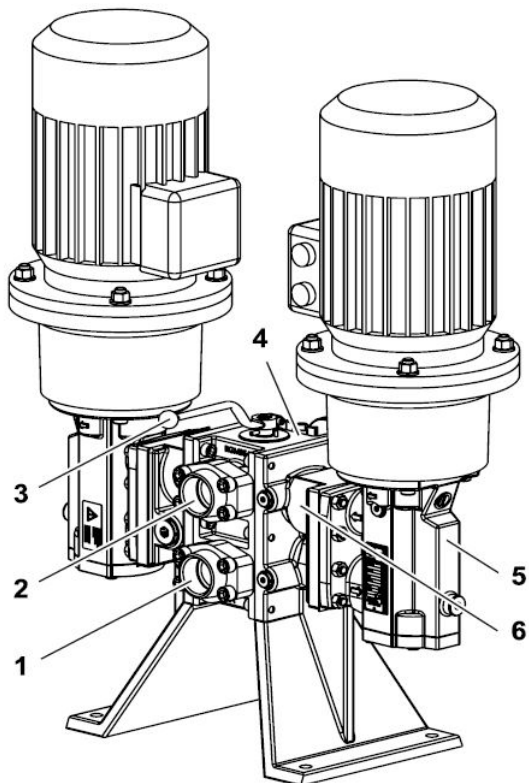

Figure 4: DALP-C pump station - front side

- 1. Suction connection
- 2. Pressure connection
- 3. Reversing valve lever
- 4. Control block

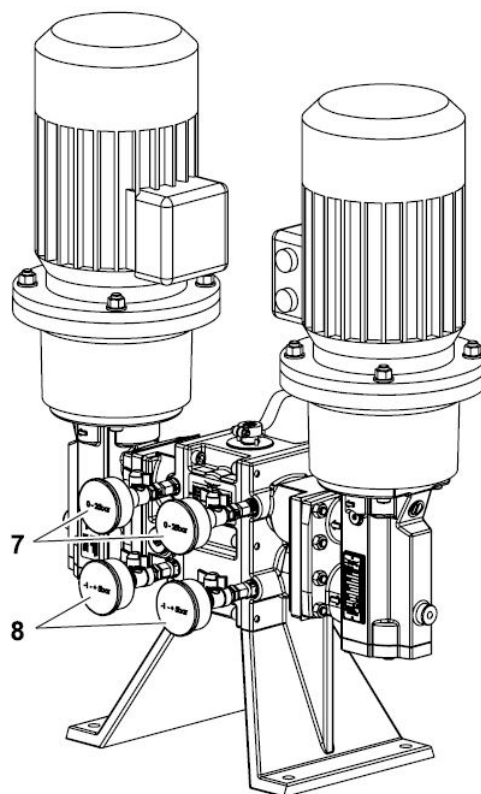

Figure 5: DALP-C pump station - rear side

- 5. Pump
- 6. Main housing
- 7. Pressure-side pressure gauge
- 8. Suction-side pressure gauge

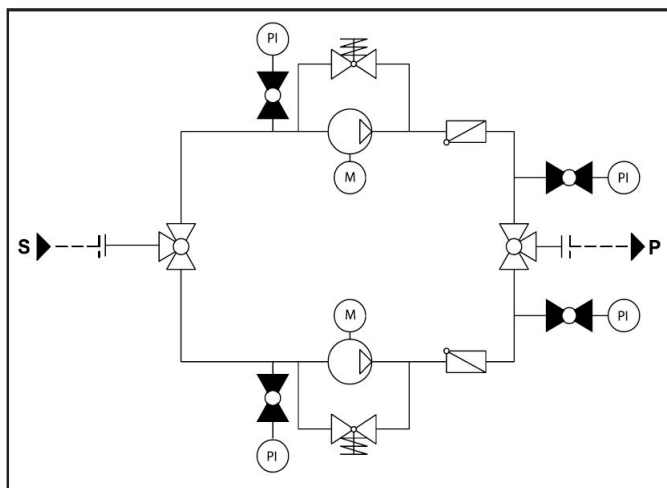

Figure 6: Hydraulic scheme

- S** Suction side
- P** Pressure side

6.1 Functional principle

The pump stations of the DALP-C series are suitable for the parallel operation of two pumps of the ALP series. The functional description of the pumps is contained in the associated pump operating instructions.

The station is connected to the pipe system by means of the suction connection 1 at the front of the station. Depending on the position of the reversing valve in the control block 4, the left-hand, the right-hand or both pumps are connected to the suction connection. There the pressure of the pumped liquid is increased and finally returns to the station through the pressure connection of the pump. The liquid flows through a non-return valve via the reversing valve to the pressure connection 2, through which the liquid leaves the station again.

6.1.1 Reversing valve

If the reversing valve lever 3 is in one of the two side positions, the respectively other line of the station is separated from the liquid circuit so that the pump of this line can be dismantled and cleaned. If the lever is in the center position, both lines are connected to the liquid circuit; refer to [Activating the reversing valve](#) on page 33. The delivery rate can thus be increased through parallel operation of the two pumps. If only one pump is being operated, the second pump can be cut in automatically if the delivery rate or the pressure drops at the active line. The non-return valves ensure that the respective pump that is stopped does not begin to rotate backwards.

6.1.2 Pressure measurement

Two pressure gauges 7 are located on the pressure sides of the two pumps in order to monitor the delivery pressure.

In order to monitor the pressure on the suction sides of the two pumps, two further pressure gauges 8 are mounted.

The stopcocks at the pressure gauges may only be opened to read the pressure values; refer to [Reading the pressure values](#) on page 34.

7 Transportation, Storage & Disposal

7.1 Unpacking and checking the state of delivery



1. Upon delivery unpack the pump station and check for transport damage.
2. Report any transport damage immediately to the manufacturer.
3. Dispose of packing materials in accordance with the locally applicable regulations.

7.1.1 Lifting the pump station

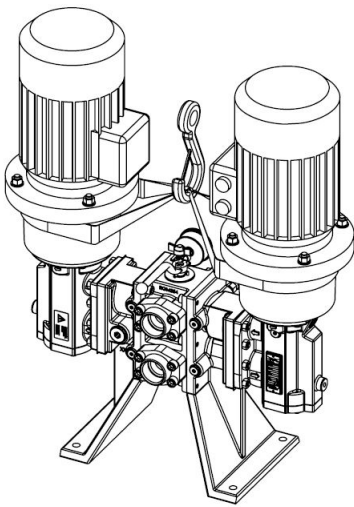

Figure 7: Attachment of hoisting equipment – schematic diagram



Risk of injury and/or damage to equipment should the pump station fall.

- ▶ Use intact and correctly dimensioned hoisting equipment suitable for the weight to be lifted.
- ▶ Choose the attachment points of the hoisting equipment according to the center of gravity and weight distribution.
- ▶ Always use at least two slings.
- ▶ Secure motors additionally against tilting.
- ▶ Do not stand under raised loads.



- ▶ Attach the hoisting equipment to the pump station and lift the pump station with a crane.

7.1.2 Storage

During the test run, the internal components of the pump station are wetted with test oil, which has a preservative effect. The pipe connections are fitted with protective covers. The external components of the pump station are preserved with a single-coat PU-based two-component paint. The preservative applied at the factory will protect the station for about six weeks, if it is stored in a dry and clean location. The manufacturer offers a long-term preservation for storage times of up to 60 months. With long term conservation the pump station is additionally packed in hermetically sealing anti-corrosion paper.

7.2 Preservation

Preservation has to be carried out in the following cases:

- **For standard delivery:** for storage periods exceeding six weeks and in case of adverse storage conditions such as high humidity, salty air, etc.
- **For delivery with long-term preservation:** if the packaging has been opened or damaged.

7.2.1 Preserving the internal surfaces of the station



1. Tilt the station so that the connections are facing upwards.
2. Fill the station block via the suction connection with non-corrosive, resin-free oil, while turning the pump slowly at the fan impeller of the motor in accordance with the arrow for the direction of rotation. Do not fill the block completely in the process, but rather leave an empty space of approx. 2 cm.
3. Attach the protective cover on the suction and pressure connection.
After about 6 months storage check the oil level in the station and top up oil if necessary.

7.2.2 Preserving the external surfaces of the station

Recommendations:

- Preservative (e.g. Castrol Rustilo DWX 33)



NOTE

Paint or spray the preservative onto all plain and unpainted parts.

At intervals of about six months, check the preservative effect and if necessary repeat preservation.

NOTE

Store the preserved station in a cool and dry place and do not expose it to direct sunlight.

7.2.3 Removing the preservation

Recommendation:

- Solvent
- Steam-jet cleaning device with wax-dissolving additives

WARNING

Risk of injury through emitted preservative oil.

- ▶ Wear protective clothing during all work.
- ▶ Remove the drain plugs with caution to relieve any pressure inside the station.
- ▶ Collect the emitted oil safely and dispose of it in an environmentally compatible manner.



1. Clean the outside of the station with solvents, if necessary using a steam-jet cleaning device.
2. Drain the station, collecting the preservative oil in a suitable vessel.
3. To remove the residual oil, remove the blind flanges and rinse the station with the pumped liquid.

7.3 Disposing of the station

Recommendations:

- Solvents or industrial cleaners suitable for the pumped liquid.



Danger of poisoning and damage to the environment from the pumped liquid.

- ▶ Wear protective clothing during all work.
- ▶ Collect the discharging pumped liquid and dispose of it in accordance with the locally applicable regulations.
- ▶ Neutralize any residues of the pumped liquid.



1. Disassemble the station.
2. Clean residues of the pumped liquid from the individual parts.
3. Separate sealing elements made of elastomers from the station and dispose of them in the residual waste.
4. Recycle metal parts.

8 Installation, Removal & Connection

8.1 Installation



The following instruction should be observed:

- When selecting the location take the operating limits, NPSH values and ambient conditions into account; refer to *Technical Data* on page 13.
- The function, safety and service life may not be impaired by humidity, temperature influences or explosive atmospheres.
- During the installation ensure that all the parts of the station can be accessed easily and that the maintenance work can be carried out easily.

8.1.1 Installing the station

The station is operated in a vertical mounting position.

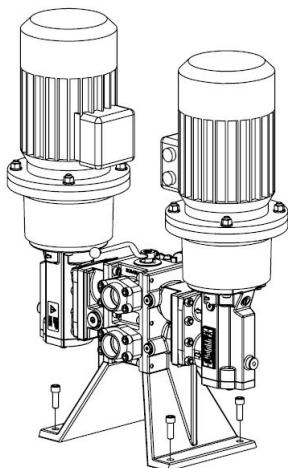

Figure 8: Mounting position DALP-C

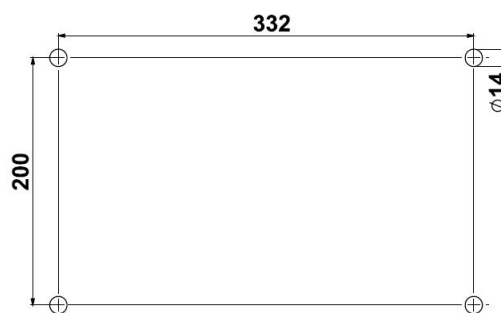

Figure 9: Drilling pattern

Pre-requisite:

- The station connections are to be protected against contamination, for example by using protective covers.



Damage to the station and piping through insufficient fastening.

- ▶ Only fasten the station on a stable load bearing surface.
 - ▶ Ensure that the fastening elements are tightened properly.
1. Place the station in position.
 2. Fasten the station with fastening elements securely to the mounting surface.

8.1.2 Protect the station against contamination



Damage through impurities in the pipe system.

- ▶ During welding work attach protective covers in front of the connecting flanges.
- ▶ Ensure when welding that welding beads and abrasive dust cannot get into the pipe system and the station.



- ▶ After the connecting work carefully clean the pipe system; refer to [Cleaning the pipe system](#) on page 29.

8.1.3 Connecting the station to the pipe system

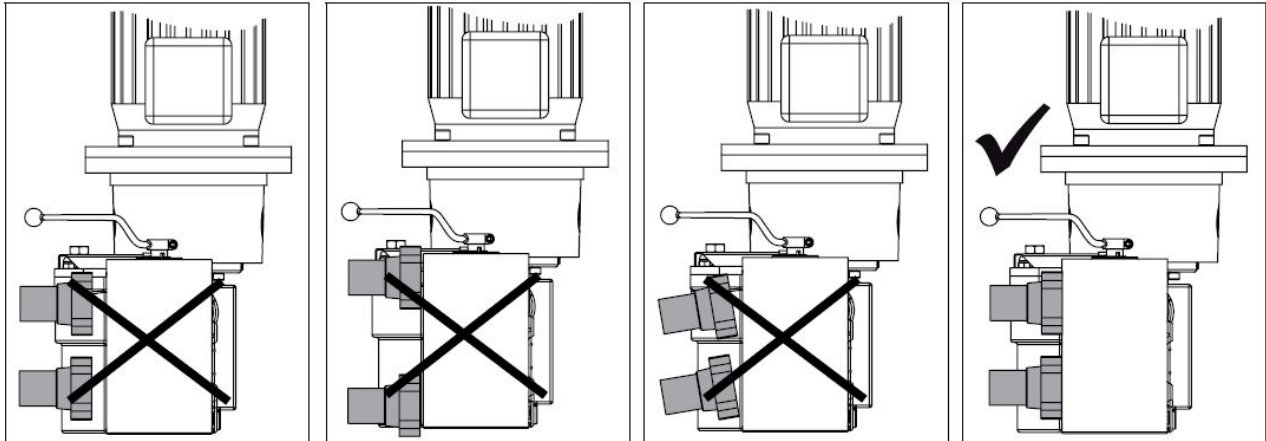

Figure 10: Connecting the station to the pipe system

CAUTION

Danger of damage to the device or impaired functionality through mechanical stresses.

Ensure that the pipe system is free of mechanical stress.



1. Check whether the reversing valve moves easily. When the reversing valve lever cannot be turned by hand, remedy the fault before installing the station.
2. During welding work attach protective covers to the connecting flanges.
3. Place the piping in position and support the weight of the piping.
4. Check the clearance and the angular, vertical and linear offset, adjusting where necessary.
If the screws tighten easily, this is a sure sign that the installation is stress-free.
5. Tighten the connecting screws crosswise with torque; refer to [Tightening torques](#) on page 52.

8.2 Removal

Recommendations:

- Vessels for leaking pumped liquid.



Risk of death resulting from electric shock.

- ▶ Ensure that the power supply is disconnected.
- ▶ The motor may only be separated from the power supply by an authorized electrician.



Risk of injury through emitted hot, poisonous or corrosive pumped liquid.

- ▶ Wear protective clothing during all work.
- ▶ Before carrying out work let the station cool down to the ambient temperature.
- ▶ Ensure that the station is depressurized.
- ▶ Collect the pumped liquid safely and dispose of it in an environmentally compatible manner.



1. Disconnect the motors from the power supply and secure them against being switched back on.
2. Close the pressure-side and suction-side shut-off devices.
3. Loosen the suction and pressure connection of the station
4. After the liquid has been drained completely, dismantle the suction-side and pressure-side flanges.
5. Open the drain screws of the station block. Collect the emitted liquid safely and dispose of it in an environmentally compatible manner.
6. Dismantle the station.

9 Operation

9.1 Commissioning



The following instructions must always be observed.

- ▶ The station may only be commissioned by authorized qualified personnel.
- ▶ Wear protective clothing during all work.

9.1.1 Cleaning the pipe system

To protect the station against particle contamination the complete pipe system has to be cleaned carefully before initial commissioning. If this is to be realized by rinsing using the station, an additional commissioning filter has to be installed before the station. .

Table 7: Commissioning filter mesh width

Options	Usage	Mesh width [mm]
Commissioning filter	Protection of the station during commissioning.	0.02



Damage to the station through additional pressure loss in the commissioning filter.

- ▶ Calculate the flow resistance and determine the remaining suction capacity.
- ▶ Monitor the suction-side pressure.
- ▶ Check and clean the commissioning filter regularly.



- ▶ Recommended operating duration for rinsing with commissioning filter: 50 – 100 hours.

9.1.2 Filling and venting the station

It is possible to fill the station via suction or pressure connection.

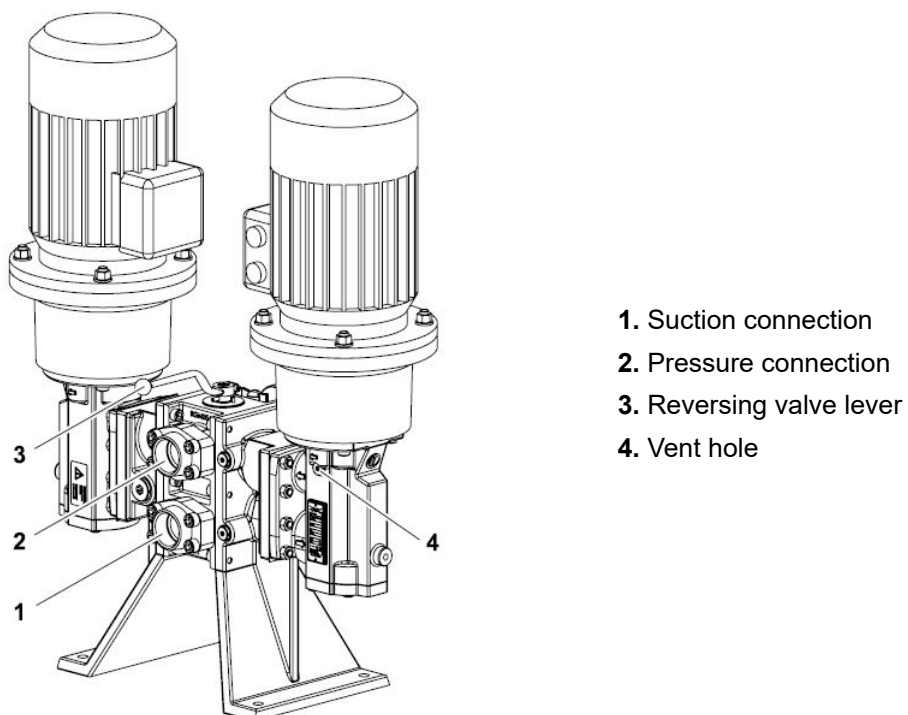

Figure 11: Filling pump

Pre-requisite

- Reversing valve lever **3** in the center position.

9.1.3 Filling the station via the suction or pressure connection



Danger of injury or poisoning through dangerous pumped liquids.

► Collect the emitted pumped liquid safely and dispose of it in an environmentally compatible manner.



1. Open the screw plugs of the vent holes 4 on the pump housings by a max. of 2 rotations so that the air can escape during the filling process.
2. Open the suction or pressure-side shut-off device and fill the pump via the suction or pressure connection until pumped liquid is emitted at the vent holes.
3. During the filling process turn the pump shaft or the fan impeller of the motors by hand to speed up the filling process:
 - Filling via pressure connection **2**: Turn the pump shaft against the direction of rotation of the motor.
 - Filling via suction connection **1**: Turn the pump shaft in the direction of rotation of the motor.
4. Tighten the screw plugs of the vent holes again.

9.1.4 Commissioning the station

Pre-requisites:

- Station set up and mounted correctly.
- Motor connected correctly.
- Pipe system is free of contamination.
- Any stopcocks in the suction and pressure opened.



Danger of injury through emitted pumped liquid.

- ▶ Wear protective clothing during all the work.
- ▶ Ensure that all the connections are connected sealingly.



Dry running can damage station equipment.

- ▶ Ensure that the station is filled properly.
- ▶ If the station does not deliver after 10 – 15 seconds, abort commissioning.



1. Switch on the station. The station will deliver when the pressure on the pressure side of the station rises or a system-side flow indicator triggers.
2. If the station does not deliver after 10 – 15 seconds of operation, abort initial commissioning, establish the cause of the fault and only then continue the commissioning procedure. Follow the instructions in the fault table; refer to [Troubleshooting](#) on page 43.
3. Run the station for a few minutes to allow the pipe system to vent fully. The pipe system is fully vented when there is a smooth operating noise and a pressure gauge on the pressure side of the station shows no more fluctuations.

9.2 During operation

9.2.1 Activating the reversing valve

Figure 12: Reversing valve

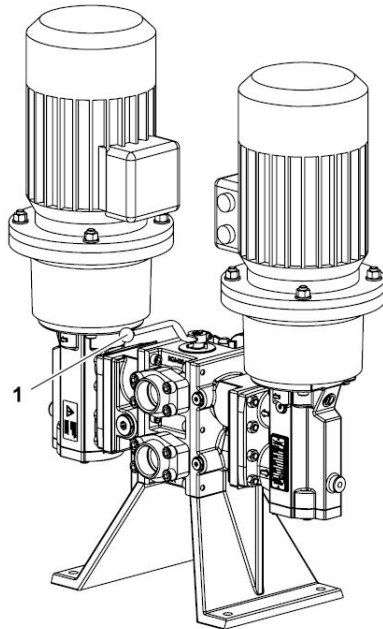

1. Reversing valve lever

9.2.2 Possible positions of the reversing valve

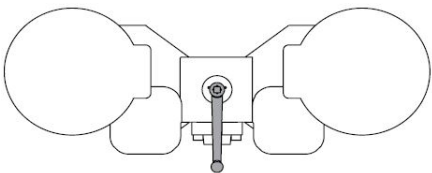
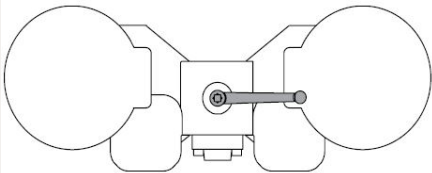
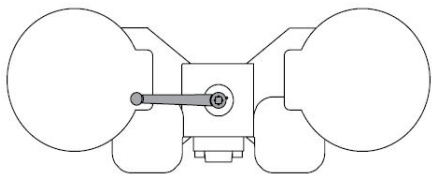
Position	Description	Effect
	Lever in center position	Both pumps connected to pipe system.
	Lever in right-hand position	Right-hand pump connected to pipe system.
	Lever in left-hand position	Left-hand pump connected to pipe system.

NOTE

The reversing valve can be switched while the station is operating.

9.2.3 Reading the pressure values

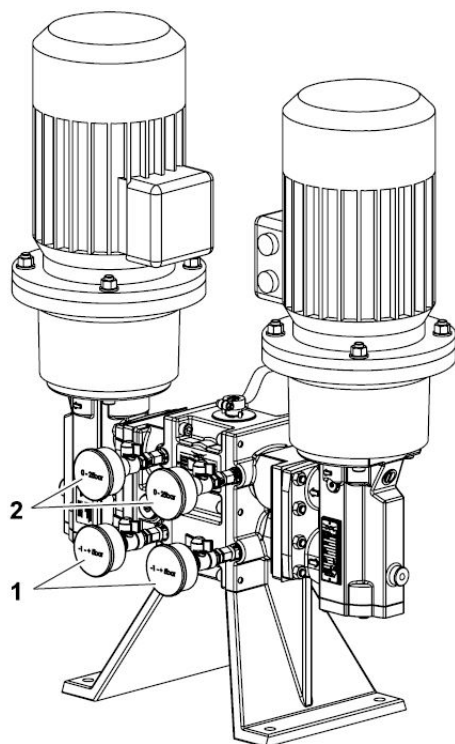

1. Suction-side pressure gauge
2. Pressure-side pressure gauge

Figure 13: Pressure gauges

CAUTION

Stopcocks that are opened permanently can result in the pressure gauges leaking.

- ▶ Close the pressure gauge stopcocks after reading.



- ▶ Always close the pressure gauge stopcocks after reading the pressure value.

Switching off the station



Damage to seals through pressurizing of the station while it is standing still.

► Ensure that while the station is at a standstill, the pressure in the pump does not exceed the feed pressure during operation.



1. Switch off the motors.
2. Close the pressure-side and suction-side shut-off devices.

9.3 Taking the station out of operation



Risk of injury or poisoning through emitted pumped liquid.

- ▶ Wear protective clothing during all work.
- ▶ Collect the emitted pumped liquid safely and dispose of it in an environmentally compatible manner.



- ▶ Carry out the following measures during shutdowns:

Table 8: Measures for operation interruption

Station is	Measure
Shut down for longer period	Depending on the pumped liquid. Refer to table below.
Drained	Close the pressure-side and suction-side shut-off devices.
Dismantled	Disconnect the motors from the power supply and secure them against being switched back on.
Stored	Observe measures for storing and preservation; refer to Storage on page 22 & refer to Preservation on page 22.

Table 9: Measures depending on behaviour of the pumped liquid

Behaviour of the pumped liquid	Duration of the shut down	
	Short	Long
• Sediment solids	▶ Rinse the station.	▶ Rinse the station.
• Congealed/frozen • No corrosive burden	▶ Heat or drain the station.	▶ Drain the station.
• Congealed/frozen • Corrosive burden	▶ Heat or drain the station.	▶ Drain the station. ▶ Preserve the station.
• Remains liquid • No corrosive burden	-	-
• Remains liquid • Corrosive burden	-	▶ Drain the station. ▶ Preserve the station.



▶ Drain the station via the pressure and suction line and screw plug and vent screws.



▶ Carry out all the steps as for the commissioning process; refer to [Commissioning](#) on page 29.

10 Maintenance

10.1 Safety instructions on maintenance and repairs

! NOTE

The following safety instructions must be observed during all work.

- ▶ All work may only be carried out by authorized qualified personnel.
- ▶ Wear protective clothing during all work.
- ▶ Switch off the motors and secure them against being switched back on.
- ▶ Before beginning work let the station cool down to the ambient temperature.
- ▶ Ensure that the station is depressurized.
- ▶ Collect the emitted pumped liquid safely and dispose of it in an environmentally compatible manner.
- ▶ Also observe the general drawings during all work; refer to [General drawing](#) on page 51.

10.1.1 Required maintenance

The service life of the station depends to a great extent on the operating conditions. If the operating limits are observed (refer to *Technical Data* on page 13) the station has a service life of many years.

Signs of progressive wear of individual station elements:



Table 10: Check table for required maintenance

Finding	Cause	Elimination
Increased running noises.	Incipient damage to bearing.	Replace the bearing.
Increased leaking.	Incipient damage to seal.	Replace the shaft seal.
Deposits on the seal.	Non-volatile liquids.	Clean the seal.
Increased play in the shaft coupling.	Advanced wear of the spider.	Replace the spider.
Reduction in the flow rate or pressure under constant operating conditions.	Advanced wear of screws and housing.	Replace the pump.



1. Check the pump visually and acoustically every four weeks.
2. Check for signs of wear as listed in the table above and eliminate the cause.
3. Also observe the corresponding pump operating instructions.

10.2 Replacing pump

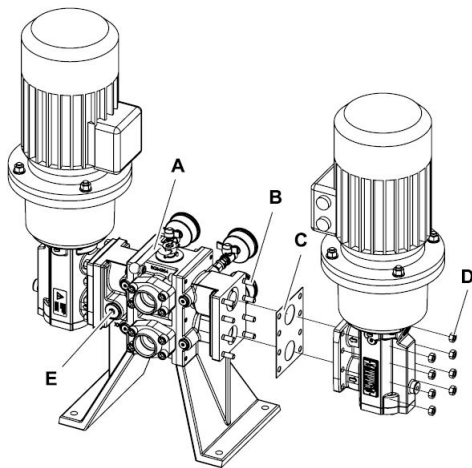

Figure 14: Overview – rear side

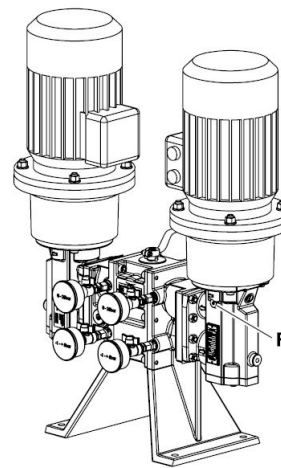

Figure 15: Overview – rear side

A Reversing valve lever

B Stud screw

C Flat gasket

D Hexagon nut

E Screw plug

F Screw plug



WARNING

Risk of injury when replacing the pump without reducing the pressure beforehand.



- Open the screw plug **F** in order to reduce the inner pressure in the housing.



WARNING

Risk of injury through emitted hot, poisonous or corrosive pumped liquid.



- Observe the safety regulations for handling dangerous liquids.



- Switch over the reversing valve lever **A** in order to shut off the respective side; refer to [Activating the reversing valve](#) on page 33.

- Open the screw plug **F** on the affected pump in order to reduce the inner pressure in the housing.

- ▶ Open the screw plug **E** on the affected main housing in order to drain the liquid from the pump.
- ▶ Loosen the hexagon nuts **D** at the pump flange, dismantle the pump and remove the flat gasket **C**.
- ▶ Clean the sealing surface and place on a new flat gasket.
- ▶ Place on the new pump on the stud screws **B**, place and tighten the hexagon nuts.
- ▶ Close the screw plug on the main housing.
- ▶ Close the screw plug on the pump and fill and vent the station; refer to [Filling and venting the station](#) on page 30.

11 Troubleshooting

11.1 Possible faults

Faults can have different causes. The following tables list the symptoms of a fault, the possible causes and measures for elimination.



Fault	Cause/Remedy
No pump suction	1, 2, 3, 4, 5, 6, 7, 31, 32
Delivery rate too low	2, 3, 4, 8, 9, 10, 11, 12, 13, 14, 15, 16, 32, 34, 35
Pump runs noisily	2, 3, 4, 9, 10, 12, 14, 18, 19, 20, 21, 32
Motor overload	8, 10, 13, 21, 22
Uneven delivery rate	2, 3, 4, 10, 12, 14, 15
Leaking shaft seal	17, 23, 24, 25, 26, 33
Pump has seized up	27, 28, 29, 30

11.2 Troubleshooting



Table 11: Fault table

No.	Cause	Remedy
1	Pump suction pipe closed	<ul style="list-style-type: none"> ▶ Check shut-off devices in the suction pipe. ▶ Open the closed shut-off devices.
2	Suction valve or pipe obstructed	<ul style="list-style-type: none"> ▶ Check the suction valve and pipe for clear passage.
3	Suction pipe or shaft seal leaks	<ul style="list-style-type: none"> ▶ Check suction pipe or shaft seal for leaks. Pay particular attention to leakage at valves and connection points. ▶ Replace leaking parts.
4	Suction head too high	<ul style="list-style-type: none"> ▶ Reduce difference of level or ▶ Reduce pipe length or ▶ Increase pipe diameter or ▶ Heat the liquid.
5	Level of liquid in the intake container too low	<ul style="list-style-type: none"> ▶ Top up the pumped liquid.
6	Pump suction capacity reduced by inadequate wetting	<ul style="list-style-type: none"> ▶ Fill pump with liquid.
7	Incorrect pump direction of rotation	<ul style="list-style-type: none"> ▶ Carry out the electrical connection so that the direction of pump rotation matches that of the arrow on the flange cover.
8	Differential pressure too high	<ul style="list-style-type: none"> ▶ Check the system and reduce the differential pressure.

No.	Cause	Remedy
9	Magnetic coupling broken off	<ul style="list-style-type: none"> ▶ Stop the pump and restart. ▶ Avoid excessive differential pressures. ▶ At repeated occurrence check whether pump has seized up.
10	Viscosity of the pumped liquid too high	<ul style="list-style-type: none"> ▶ Increase the temperature of the liquid or ▶ Reduce the rotation speed.
11	Viscosity of the pumped liquid too low	<ul style="list-style-type: none"> ▶ Decrease the temperature of the liquid or ▶ Increase the rotation speed.
12	Airlock or gas in the liquid	<ul style="list-style-type: none"> ▶ Test the pipe system for ingress of air and re-place parts if necessary. ▶ Reduce the suction head or increase the feed pressure.
13	Motor running at wrong voltage or frequency	<ul style="list-style-type: none"> ▶ Ensure that the motor voltage and frequency match the operating voltage. ▶ Compare the speed of the motor with the pump communication plate. If the data does not match, adjust the speed of the motor.
14	Pressure relief valve opens during normal operation	<ul style="list-style-type: none"> ▶ Reduce operating pressure.
15	Pressure relief valve leaks	<ul style="list-style-type: none"> ▶ Clean the pressure relief valve and reseal if necessary.
16	Advanced wear of rotating pump components	<ul style="list-style-type: none"> ▶ Check screw set and housing and replace damaged parts.
17	Advanced wear of sealing surfaces	<ul style="list-style-type: none"> ▶ Replace the seal. ▶ Check the pumped liquid for abrasive content.
18	Pump distorted	<ul style="list-style-type: none"> ▶ Support the weight of the piping. ▶ Loosen pipe connections and mount stress-free; refer to Connecting the station to the pipe system on page 27.
19	Resonance in the system	<ul style="list-style-type: none"> ▶ Place the pump station elastically or ▶ Make the connections with hoses.
20	Speed of flow in suction or pressure pipe too high	<ul style="list-style-type: none"> ▶ Set the flow speed in the suction pipe so that it does not exceed 1 m/s. ▶ Set the flow speed in the pressure pipe so that it does not exceed 3 m/s.
21	Ball bearing damaged	<ul style="list-style-type: none"> ▶ Replace the ball bearing, see the section "Maintenance" of the corresponding pump operating instructions.
22	Lack of lubrication or foreign bodies have caused superficial damage to rotating pump components	<ul style="list-style-type: none"> ▶ Check the screw set and the housing. ▶ If necessary replace the pump.
23	Dry running has damaged the shaft seal	<ul style="list-style-type: none"> ▶ Replace the shaft seal, see the section "Maintenance" of the corresponding pump operating instructions. When starting up the pump, pay attention to venting.
24	Feed pressure too high	<ul style="list-style-type: none"> ▶ Reduce the feed pressure at the system.
25	Thermal or chemical loading of elastomer seals exceeded	<ul style="list-style-type: none"> ▶ Check the maximum operating temperature. ▶ Check the resistance of the elastomers with regard to the pumped liquid.
26	Cold start when delivering high-viscosity liquids	<ul style="list-style-type: none"> ▶ Preheat the pumped liquid.

No.	Cause	Remedy
27	Foreign bodies in the pump	<ul style="list-style-type: none"> ▶ Dismantle the pump and clean it. ▶ Smooth the superficial damage to the housing and the rotating parts with an oilstone. ▶ If necessary, replace the pump.
28	Differential pressure is too high and has overloaded the screws	<ul style="list-style-type: none"> ▶ Dismantle the pump and clean it. ▶ Smooth the superficial damage to the housing and the rotating parts with an oilstone ▶ Reduce the differential pressure. ▶ If necessary, replace the pump.
29	Viscosity is too low and has overloaded the screws	<ul style="list-style-type: none"> ▶ Dismantle the pump and clean it. ▶ Smooth the superficial damage to the housing and the rotating parts with an oilstone. ▶ Increase the viscosity, for example by reducing the operating temperature. ▶ If necessary, replace the pump.
30	Dry running has damaged the pump equipment	<ul style="list-style-type: none"> ▶ Dismantle the pump and clean it. ▶ Smooth the superficial damage to the housing and the rotating parts with an oilstone. ▶ When resuming operation, take action to prevent dry running; refer to <i>Taking the station out of operation</i> on page 36. ▶ If necessary, replace the pump.
31	Pump does not vent	<ul style="list-style-type: none"> ▶ Vent the pressure pipe at the highest point.
32	Reversing valve lever in the incorrect position	<ul style="list-style-type: none"> ▶ Place the reversing valve lever in the correct position.
33	If particles enter, the molded gaskets could be damaged due to the abrasive action, compromising the valve seal with the result that it no longer insulates.	<ul style="list-style-type: none"> ▶ In case of lack of insulation, the balls must be inspected and the molded gaskets replaced. Refer to <i>Molded gasket kit</i> on page 49.
34	Stand-by pump rotate anti-clockwise while the other pump is in operation.	<ul style="list-style-type: none"> ▶ Part of the delivered flow is recirculated through the stand-by pump; check stand-by pump non-return valve. Refer to <i>Non-return valve kit</i> on page 50.
35	Pump in operation is not able to deliver required pressure.	<ul style="list-style-type: none"> ▶ Part of the delivered flow may be recirculated through the stand-by pump; check stand-by pump non-return valve. Refer to <i>Non-return valve kit</i> on page 50.

12 Spare part kits

! NOTE

Spare part kits contain the numbered parts only.

Spare part kits are supplied complete only.

12.1 Maintenance kit - Station, without strainer

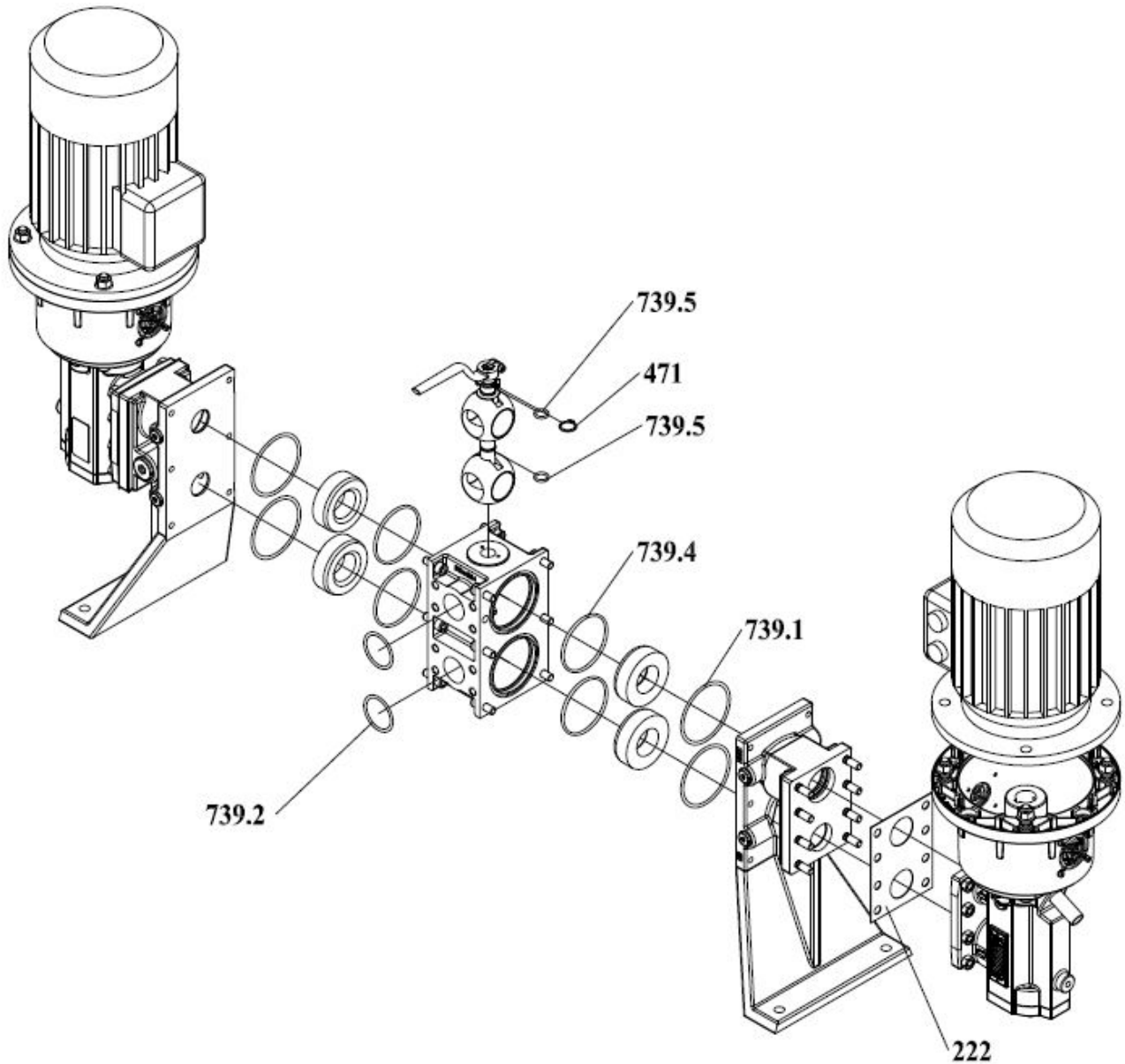

Figure 16: DALP-C 0015-0085 Maintenance kit – Station, without strainer

Table 12: DALP-C 0015-0085 Maintenance kit - Station, without strainer

DALP-C 0015-0085			
Denomination	Qty.	Dimensions	Pos. no.
Maintenance kit - Station, without strainer 9014390 81	1		
Flat gasket ALP 0015-0020	2	113x 82x 1.00	222
Flat gasket ALP 0030-0040	2	133x115x 1.00	222
Flat gasket ALP 0055-0085	2	154x115x 1.00	222
Circlip	1	20 x 1.20	471
O-ring	4	85.32 x 3.53	739.1
O-ring	2	47.22 x 3.53	739.2
O-ring	4	78.97 x 3.53	739.4
O-ring	2	15.08 x 2.62	739.5

12.2 Molded gasket kit

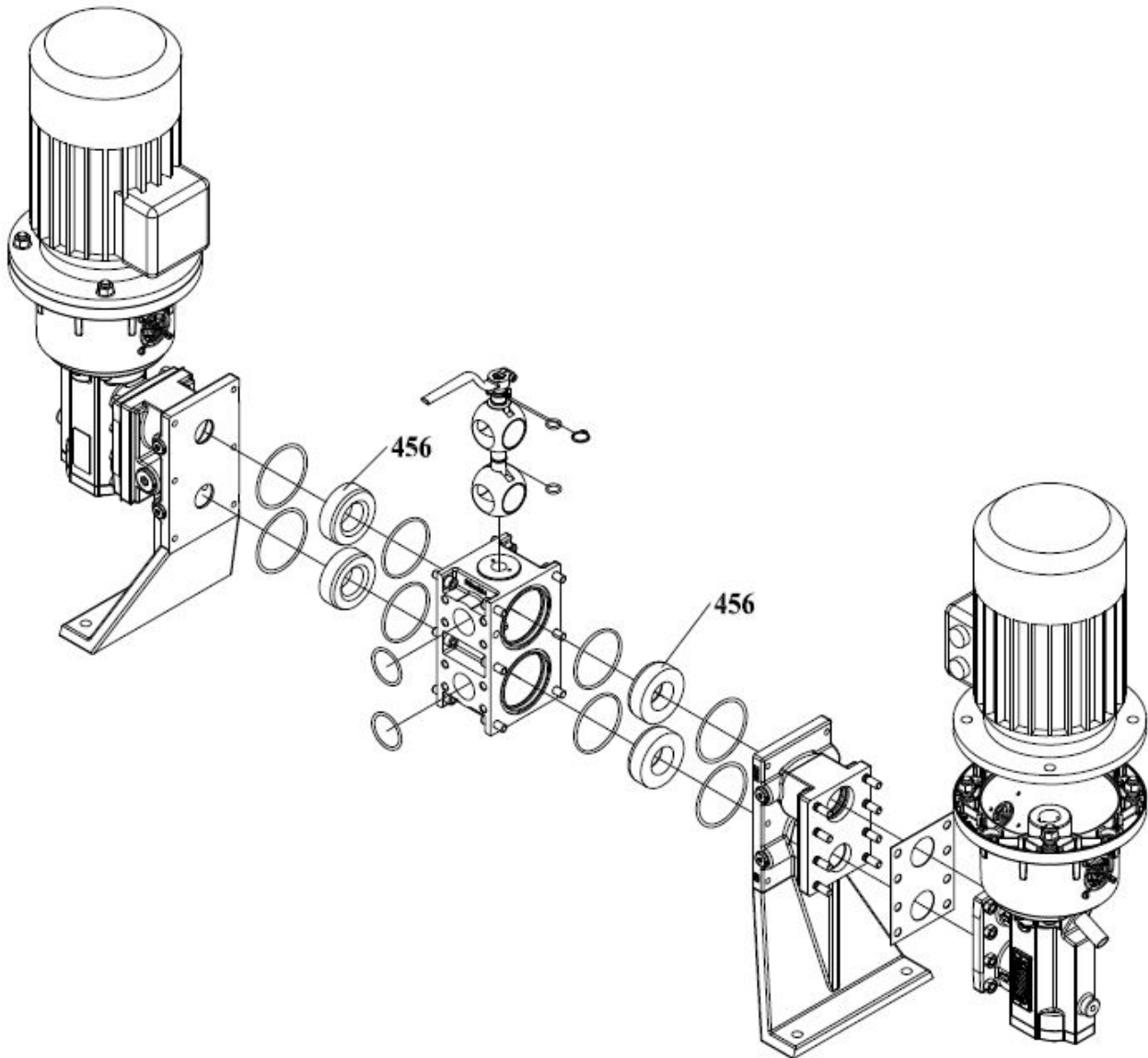

Figure 17: DALP-C 0015–0085 Molded gasket kit

Table 13: DALP-C 0015-0085 Molded gasket kit

DALP-C 0015–0085			
Denomination	Qty.	Dimensions	Pos. no.
Molded gasket kit 9041755 80	1		456

12.3 Non-return valve kit

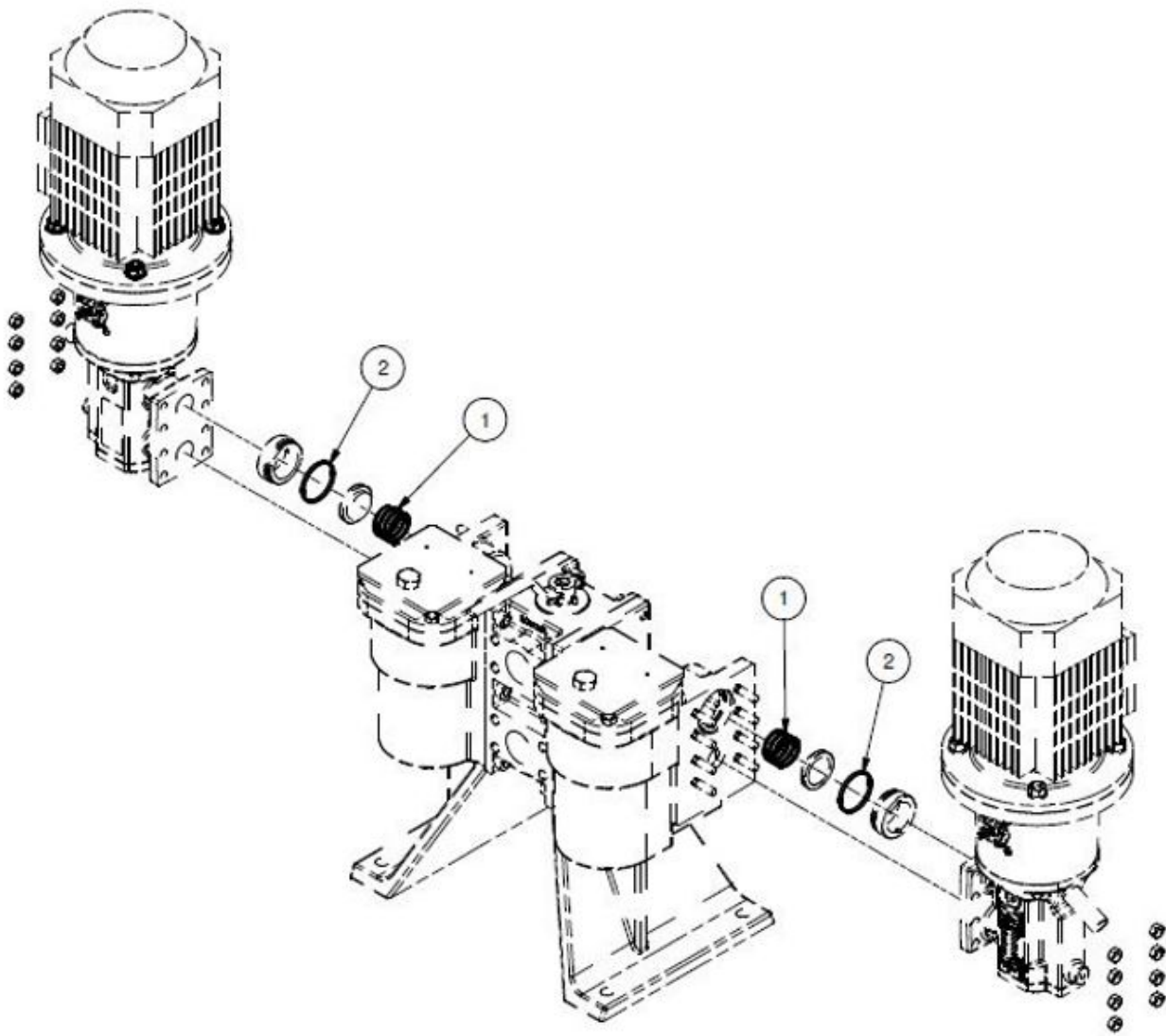

Figure 18: Non-return valve kit

Table 14: DALP-C 0015-0085 Non-return valve kit

DALP-C 0015-0085		
Denomination	Qty.	Note
Non-return valve kit 9056727	1	Including: <ul style="list-style-type: none"> • 2x cylindrical spring (Pos.1) • 2x O-ring (Pos.2)

13 Appendix

13.1 General drawing

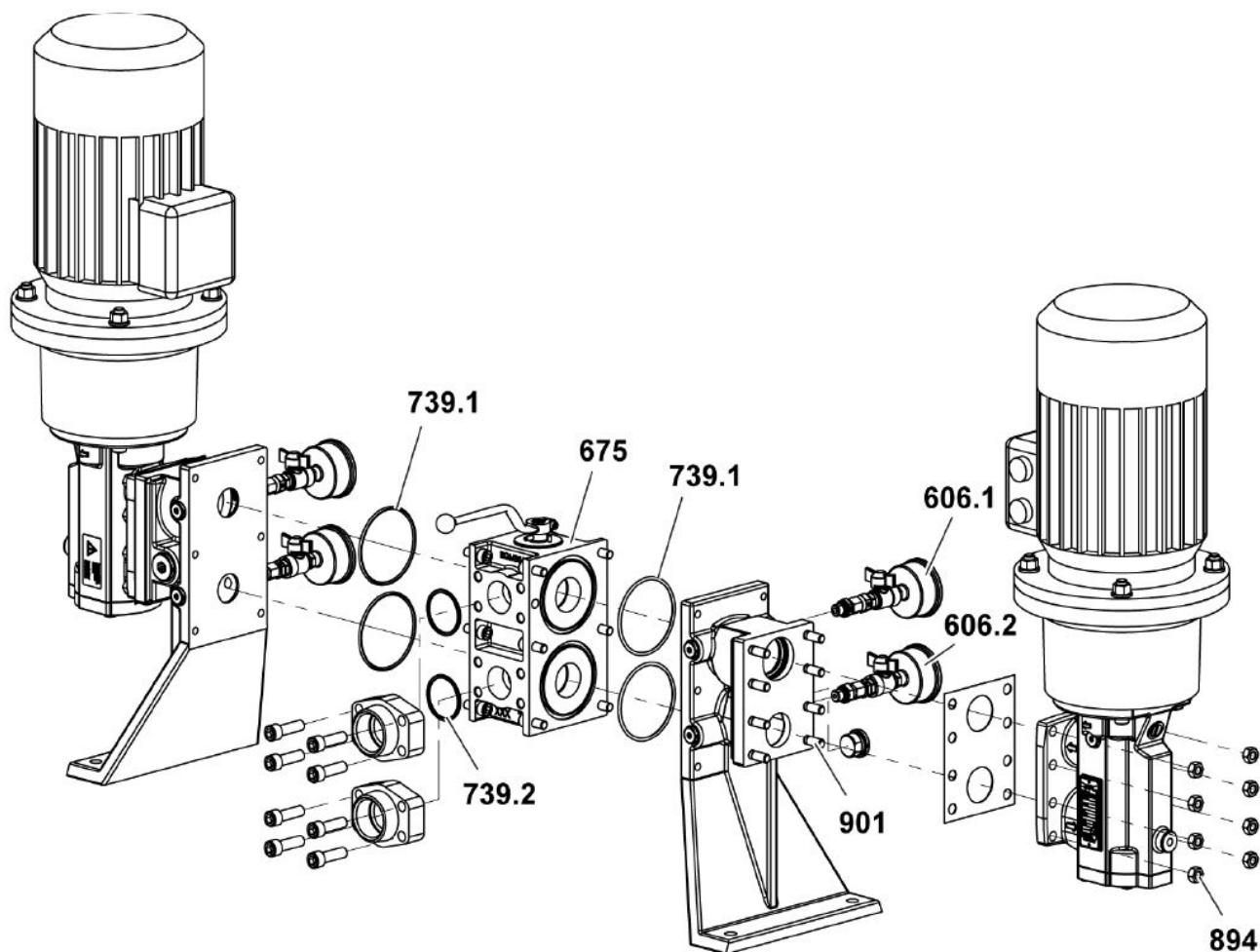

Figure 19: DALP-C pump station

Parts table

Table 15: Parts numbers

Pos. no.	Denomination	Pos. no.	Denomination
606.1	Pressure-side pressure gauge	739.2	O-ring
606.2	Suction-side pressure gauge	894	Hexagon nut
675	Control block	901	Stud screw
739.1	O-ring		

13.2 Tightening torques

Table 16: Tightening torques

Tightening torque [Nm] for screws with metric threads + head contact surfaces									with thread measured in inches	
	5.6	8.8	+ wedge lock washers			Stainless steel screws A2 and A4			Screw plugs with elastomer seal	
			10.9	8.8 + Alu*	8.8	Rust-proof A4-70	Property class 70	Property class 80	Thread	Galvanized + stainless steel
M 3	0.6	1.5	–	1.2	1.5	1.1	–	–	G 1/8"	13
M 4	1.4	2.9	4.1	2.3	3	2	–	–	G 1/4"	30
M 5	2.7	6.0	8.0	4.8	6.0	3.9	3.5	4.7	G 3/8"	60
M 6	4.7	9.5	14	7.6	10.3	6.9	6	8	G 1/2"	80
M 8	11.3	23.1	34	18.4	25	17	16	22	G 3/4"	120
M 10	23	46	68	36.8	47	33	32	43	G 1"	200
M 12	39	80	117	64	84	56	56	75	G 1 1/4"	400
M 14	62	127	186	101	133	89	–	–	G 1 1/2"	450
M 16	96	194	285	155	204	136	135	180		
M 18	133	280	390	224	284	191	–	–	reduced tightening torque when screwing into aluminium	
M 20	187	392	558	313	399	267	280	370		
M 24	322	675	960	540	687	460	455	605		