

Screw pumps ALP Sizes 0015–0085 Magnetic coupling M-type

Operating Instructions



Lit. Code
Manual No.

200007721-1-EN-GB
9062570 02

Component Description

Published by
Alfa Laval SpA
Product Development FCS & Modules
Via Pusiano 2
20900 Monza (MB), Italy

The original instructions are in English

© Alfa Laval Corporate AB 2022-09

This document and its contents are subject to copyrights and other intellectual property rights owned by Alfa Laval Corporate AB. No part of this document may be copied, re-produced or transmitted in any form or by any means, or for any purpose, without Alfa Laval Corporate AB's prior express written permission. Information and services provided in this document are made as a benefit and service to the user, and no representations or warranties are made about the accuracy or suitability of this information and these services for any purpose. All rights are reserved.

Contents

1	Warning signs in text	7
1.1	Warning signs	7
2	About this document	9
2.1	General information.....	9
2.2	Target groups	9
2.3	Symbols.....	9
2.4	Associated documents.....	9
3	Safety	11
3.1	Proper use	11
3.2	Safety information.....	12
3.3	Safety instructions for magnetic coupling systems.....	13
4	Labelling	15
4.1	Type code	15
4.2	Communication plate	16
5	Technical data	17
5.1	Operating limits	17
5.2	Required NPSH values	18
5.3	Weights.....	19
5.4	Dimensions.....	20
5.5	Capacity tables	22
5.6	Sound pressure levels	24
5.7	Overflow valve	24
5.8	Materials	24
6	Function description	25
6.1	Structure.....	25
6.1.1	Standard direction of rotation.....	26
6.1.2	Flow direction	26
6.2	Magnetic coupling	26
6.3	Overflow valve	26
7	Transportation, Storage and Disposal	27
7.1	Unpacking and checking the state of delivery	27
7.2	Lifting the pump/pump unit	27
7.3	Storage	28
7.4	Preservation	29
7.4.1	Removing the preservation	30

7.4.2	Disposing of the pump	31
8	Installation, removal and connection.....	33
8.1	Safety instruction on installation, removal and connection.....	33
8.2	Installation	33
8.3	Installing the pump	34
8.4	Protect the pump against soiling	35
8.4.1	Connecting the pump to the pipe system.....	35
8.4.2	Connecting the motor	36
8.5	Removing the pump	37
9	Operation.....	39
9.1	Commissioning.....	39
9.2	Cleaning the pipe system	40
9.3	Filling the pump.....	41
9.4	Filling the pump via the suction or pressure connection.....	42
9.5	Checking direction of rotation	43
9.6	Commissioning the pump	44
9.7	Taking pump out of operation	45
9.8	Recommissioning the pump.....	46
10	Maintenance.....	47
10.1	Safety instructions on maintenance and repairs	47
10.2	Required maintenance	48
10.3	Magnetic coupling	48
10.4	Ball bearing.....	48
10.5	Replacing the magnetic coupling	49
10.5.1	Dismantling the outer rotor	49
10.5.2	Dismantling the inner rotor.....	51
10.6	Installing the magnetic coupling.....	53
10.6.1	Mounting the inner rotor.....	53
10.6.2	Mounting the outer rotor	57
10.7	Replacing the ball bearing	59
10.7.1	Removing the ball bearing	59
10.7.2	Installing the ball bearing	61
11	Troubleshooting	63
11.1	Possible faults	63
11.2	Troubleshooting.....	64
12	Spare Parts.....	67
12.1	ALP magnetic coupling spare parts.....	67
12.2	ALP Magnetic coupling - Maintenance kit.....	68

12.2.1	ALP 0015-0020 Magnetic coupling - Maintenance kit.....	68
12.2.2	ALP 0030-0040 Magnetic coupling - Maintenance kit.....	69
12.2.3	ALP 0055-0085 Magnetic coupling - Maintenance kit.....	70
12.3	Flange gasket.....	70
12.4	Tensioning element.....	71
12.5	Valve body (cone).....	72
12.6	Cylindrical spring.....	72
12.7	Containment can.....	72
12.8	Screw plug for ALP magnetic coupling.....	73
13	Appendix	75
13.1	General drawings	75
13.2	Parts table	76
13.3	Tightening torques	77
13.4	Required tool for maintenance work.....	78
14	EC Declaration of conformity	79

1 Warning signs in text

1.1 Warning signs

Pay attention to the safety instructions in this manual. Below are definitions of the three grades of warning signs used in the text where there is a risk for injury to personnel.

**DANGER DANGER**

Indicates an imminently hazardous situation which, if not avoided, will result in death or serious injury.

**WARNING WARNING**

Indicates a potentially hazardous situation which, if not avoided, could result in death or serious injury.

**CAUTION CAUTION**

Indicates a potentially hazardous situation which, if not avoided, may result in minor or moderate injury.

**NOTE NOTE**

Indicates a potentially hazardous situation which, if not avoided, may result in property damage.



Safety



Safety

2 About this document





2.1 General information

The operating instructions form part of the pump or of the pump unit and must be kept for future reference. Further more please observe the associated documents.

2.2 Target groups

Target group	Tasks
Operator-owner	<ul style="list-style-type: none"> • Keep these instructions available at the system site for future reference. • Ensure that employees read and observe these instructions and the associated documents, in particular the safety instructions and warnings. • Observe additional system-specific directives and regulations.
Specialist personnel, fitters	<ul style="list-style-type: none"> • Read, observe and follow these instructions and the associated documents, in particular the safety instructions and warnings.

2.3 Symbols

Symbol	Meaning
	Procedures mechanical installation.
	Procedures electrical installation.
	Check or fault table.
	Safety instructions for persons with pacemakers.
	Request for action.

2.4 Associated documents

- Pump operating instructions.
- ATEX supplementary instructions for operation in potentially explosive areas.
- Declaration of conformity according to EU Directive 2006/42/EC.
- Declaration of conformity according to EU Directive 94/9/EC.
- Manufacturer's declaration as per EU Directive 97/23/EC.
- Technical documentation for supplied components.

3 Safety

3.1 Proper use

- Use the pump solely for transporting lubricating liquids that are chemically neutral and that contain no gas or solid components.
- Use the pump only within the performance limitations specified on the rating plate and in the "Technical data" section. In the case of operating data that does not agree with the specifications on the rating plate, please contact the manufacturer.
- The pump is specifically configured for the operating pressure stated by the customer. In the case of a significant difference between actual and configured operating pressure damages can occur even within the stated performance limitations. This applies both to notably higher as well as to notably lower operating pressures. In case of any doubt, please contact the manufacturer.



Safety

3.2 Safety information

NOTE

The following general safety instructions must be observed.

- No liability is accepted for damage arising through non-observance of the operating instructions.
 - Read the operating instructions carefully and observe them.
 - The operator-owner is responsible for the observance of the operating instructions.
 - Installation, removal and installation work may only be carried out by specialist personnel.
- In order for the warranty to remain valid, corrective maintenance carried out during the warranty period requires the express permission of the manufacturer.
- Observe the general regulations for the prevention of accidents as well as the local safety and operating instructions.
- Observe the valid national and international standards and specifications of the installation location.
- In case of systems with an increased potential of danger to humans and/or machines the failure of a pump may not lead to injuries or damage to property.
 - Always equip systems with an increased potential of danger with alarm equipment.
 - Maintain and check the protective/alarm equipment regularly.
- The pumped liquids can be dangerous (e.g. hot, dangerous to health, poisonous, combustible). Observe the safety regulations for handling dangerous materials.
- Pumped liquid can be subject to high pressure and can cause damage and/or personal injury should leaks occur.



Safety

3.3 Safety instructions for magnetic coupling systems.

Magnetic fields from magnetic coupling systems (MCS) can influence the function and operational safety of electrical and electronic devices.

**NOTE**

The following safety instructions must be observed.

Additional safety instructions for magnetic coupling systems.



- Keep the MCS away from pacemakers. There is a danger to life!.
 - Under no circumstances may persons with pacemakers perform installation, dismantling or maintenance work.
- Persons with pacemakers must comply with the following safe distances to the MCS:
 - 3 m distance to the openly accessible MCS.
 - 1 m distance to pump units with installed MCS.
- Do not bring the MCS in the immediate area of PCs, data carriers and other electronic components.
- Keep the MCS away from clocks, magnetized tools and measuring equipment as well as all magnetizable parts.
- Do not bring both the MCS parts together, as this can destroy the magnetic coupling system.

Safety



Safety

4 Labelling

4.1 Type code

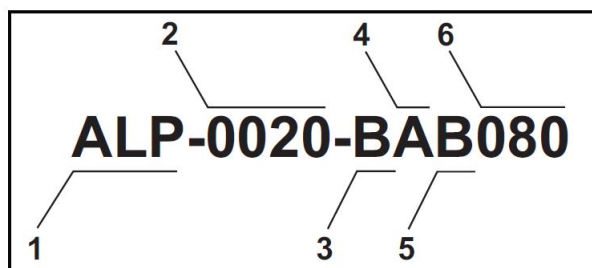

1. Model
2. Size
3. Shaft seal
4. Overflow valve
5. Completion
6. Motor size

Figure 1: Type code

Table 1: Type code

Pos.	Designation	Type	
1	Model	ALP	Single pump.
2	Size	Corresponds to flow rate in [l/min] at 1 450 min ⁻¹	
3	Shaft seal	B	Mechanical seal of hard material.
		D	Magnetic coupling. Up to April 2022.
		M	Magnetic coupling. From May 2022.
4	Overflow valve		Opening at differential pressure [bar].
		A	6 ± 10 %
		B	10 ± 10 %
5	Completion	A	Pump with free shaft end.
		B	Pump unit for vertical mounting, with pump bracket and coupling.
		C	Pump unit for horizontal mounting, with pump bracket, pump bracket foot and coupling.
		D	Pump unit for vertical mounting, with pump bracket, coupling and motor.
		E	Pump unit for horizontal mounting, with pump bracket, pump bracket foot, coupling and motor.
6	Motor size	80	
		90	
		100	
		112	
		132	

4.2 Communication plate

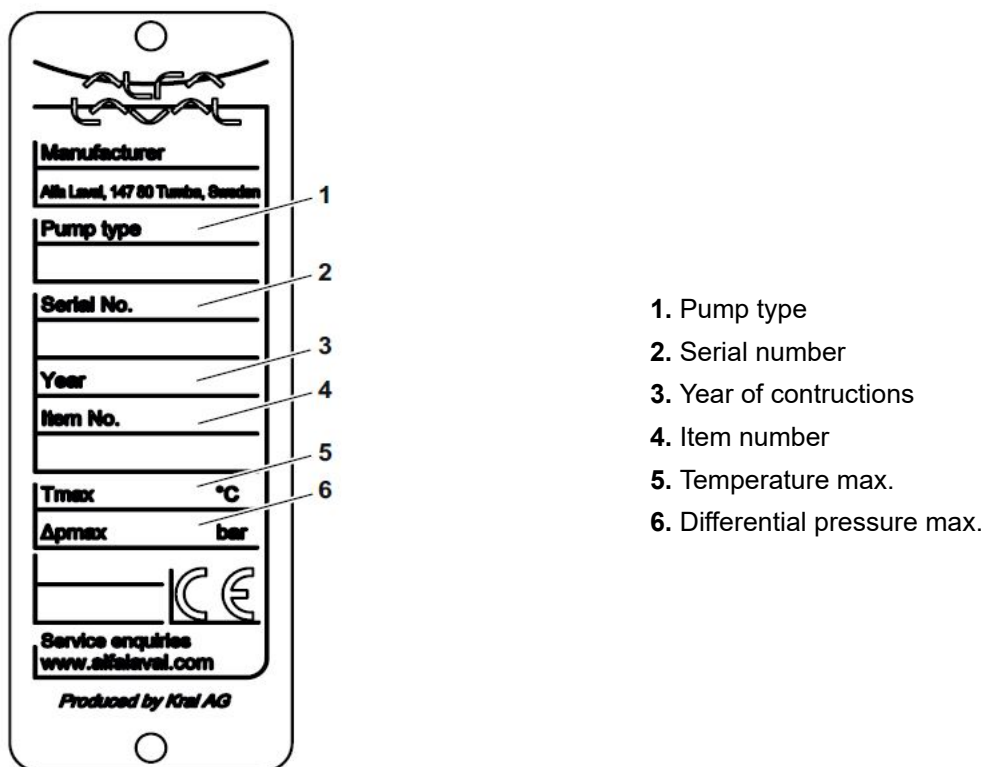

Figure 2: Rating plate

5 Technical data

5.1 Operating limits

Table 2: Operating limits

	Size 15 - 85	
	Overflow valve A	Overflow valve B
Differential pressure max. [bar]	5.4	9
End pressure max. [bar]	16	16
Valve opening pressure [bar]	6 ± 10 %	10 ± 10 %
Temperature max. [°C]	155	155
Temperature min. [°C]for pump materials	-20	-20
Viscosity min. - max. [mm ² /s]	1.4 - 10000	1.4 - 10000
Rotation speed [min ⁻¹]		
@ 50 Hz	2900	2900
@ 60 Hz	3500	3500

5.2 Required NPSH values

The following table lists the required NPSH values during operation with a low-volatile liquid such as lubricating oil or hydraulic liquid. When liquids have a readily volatile component content, the required NPSH values increase notably:

- When the pumped liquid contains water (e. g. heavy fuel oil), the values in the table have to be increased by the vapor pressure of the water at the specified operating temperature.

The required NPSH values also need to be increased if there are gas contents, regardless of whether it is dissolved or not. In case of any doubt, please contact the manufacturer.

Table 3: Required NPSH values

Size	Viscosity [mm ² /s]	NPSH value [mWC] at Rotation speed [min ⁻¹]				Size	Viscosity [mm ² /s]	NPSH value [mWC] at Rotation speed [min ⁻¹]			
		1450	1750	2900	3500			1450	1750	2900	3500
ALP 15	6	2.0				ALP 55	6	2.0			
	37	2.0					37	2.0			2.7
	152	2.0			2.2		152	2.1		2.8	3.3
	380	2.0		2.7	3.0		380	2.5	2.7	3.5	4.0
ALP 20	6	2.0				ALP 75	6	2.0		2.6	3.0
	37	2.0					37	2.0		2.9	3.4
	152	2.0		2.4	2.7		152	2.3	2.5	3.3	4.1
	380	2.2	2.4	3.2	3.8		380	2.7	3.0	4.4	5.0
ALP 30	6	2.0				ALP 85	6	2.0		2.8	3.4
	37	2.0					37	2.0		3.1	3.8
	152	2.0		2.3	2.6		152	2.4	2.6	3.8	4.6
	380	2.2	2.4	3.1	3.7		380	2.8	3.1	4.6	5.8
ALP 40	6	2.0			2.3						
	37	2.0		2.1	2.6						
	152	2.0		2.8	3.5						
	380	2.5	2.7	4.0	4.8						

5.3 Weights

Table 4: ALP weights, with magnetic coupling

Pump size	Motor size	Coupling	Pump bracket foot	Weights (kg)			Note
				Pump	Bracket	Total weight	
ALP-0015	90	10 Nm	no	8.2	5.1	13.3	
			yes		5.7	13.9	
ALP-0020	90	10 Nm	no	8.2	5.1	13.3	
			yes		5.7	13.9	
ALP-0030	90	10 Nm	no	10.5	5.1	15.6	
			yes		5.7	16.2	
ALP-0040	90	10 Nm	no	10.5	5.1	15.6	
			yes		5.7	16.2	
	100/112	20 Nm	no	11.0	6.2	17.2	
			yes		7.0	18.0	
ALP-0055	100/112	20 Nm	no	14.2	6.4	20.6	
			yes		7.2	21.4	
ALP-0075	100/112	20 Nm	no	14.2	6.4	20.6	
			yes		7.2	21.4	
	132	20 Nm	no	14.2	6.8	21.0	To be used as single pump or mounted on DALP-C
			yes		7.9	22.1	
			no	14.2	12.1	26.3	To be used only mounted on DALP-S
			yes				
ALP-0085	100/112	20 Nm	no	14.2	6.4	20.6	
			yes		7.2	21.4	
	132	30 Nm	no	14.3	6.7	21.0	To be used as single pump or mounted on DALP-C
			yes		7.8	22.1	
			no	14.3	11.9	26.2	To be used only mounted on DALP-S

5.4 Dimensions

Table 5: Dimensions ALP pump

Size	Pump [mm]											Shaft end [mm]			
	g	B1	L1	L2	L3	L4	D1	D2	D3	S1	Z1	d	l	t	u
15 - 20	73	15	50	12	60	60	128	103	75	9	4	14	30	-	-
30 - 40	73	12	50	12	68	75	135	103	75	9	4	14	30	-	-
55 - 85	83	15	50	15	75	85	160	138	75	11	4	19	35	-	-

Table 6: Dimension pump unit with magnetic coupling

Size	Motor size	Magnet power [Nm]	Pump unit [mm]												
			LP	LL	LM*	LG**	L5	L6	L7	L9	H1	B2	B3	S4	
15-20	80	75/10	157	139	*	**	60	90	19	120	12	210	180	Ø11	
	90	75/10	157	139	*	**	60	90	19	120	12	210	180	Ø11	
	90	75/20	157	139	*	**	60	90	19	120	12	210	180	Ø11	
	110/112	75/10	157	150	*	**	60	97	39	111	15	250	220	Ø13	
	100/112	75/20	157	150	*	**	60	97	39	111	15	250	220	Ø13	
30-40	80	75/10	209	139	*	**	60	90	19	128	12	210	180	Ø11	
	90	75/10	209	139	*	**	60	90	19	128	12	210	180	Ø11	
	90	75/20	209	139	*	**	60	90	19	128	12	210	180	Ø11	
	110/112	75/10	209	150	*	**	60	97	39	119	15	250	220	Ø13	
	100/112	75/20	209	150	*	**	60	97	39	119	15	250	220	Ø13	
55-85	90	75/20	226	140	*	**	60	90	19	136	12	210	180	Ø11	
	100/112	75/30	226	148	*	**	60	97	39	124	15	250	220	Ø13	
	132	75/30	226	168	*	**	60	116	40	123	18	290	260	Ø13	

* Depends on motor model.

** $LG=LP+LL+LM$

Dimensional drawings of ALP pump and pump unit

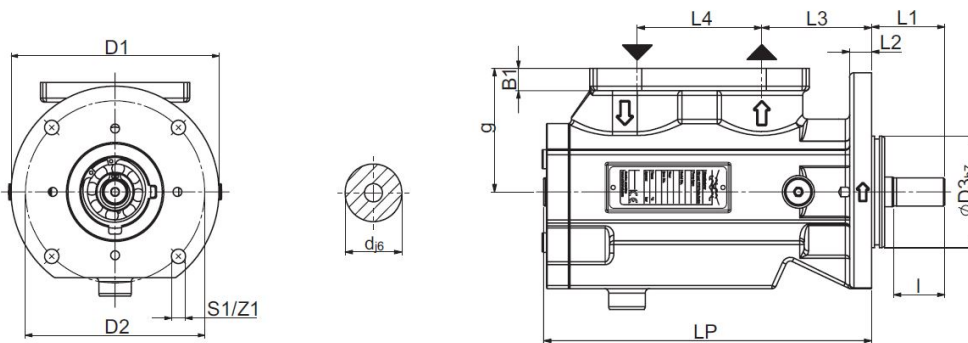

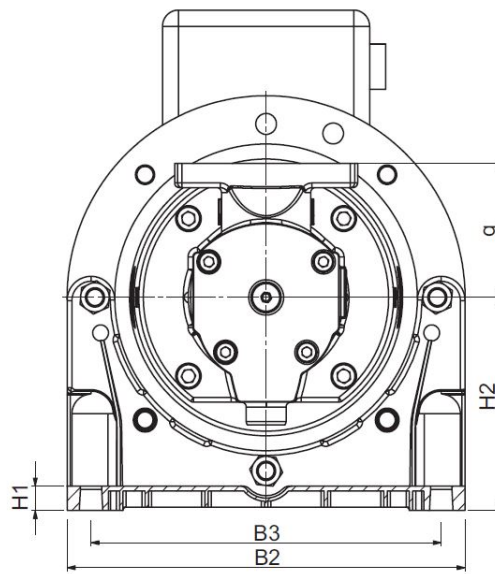
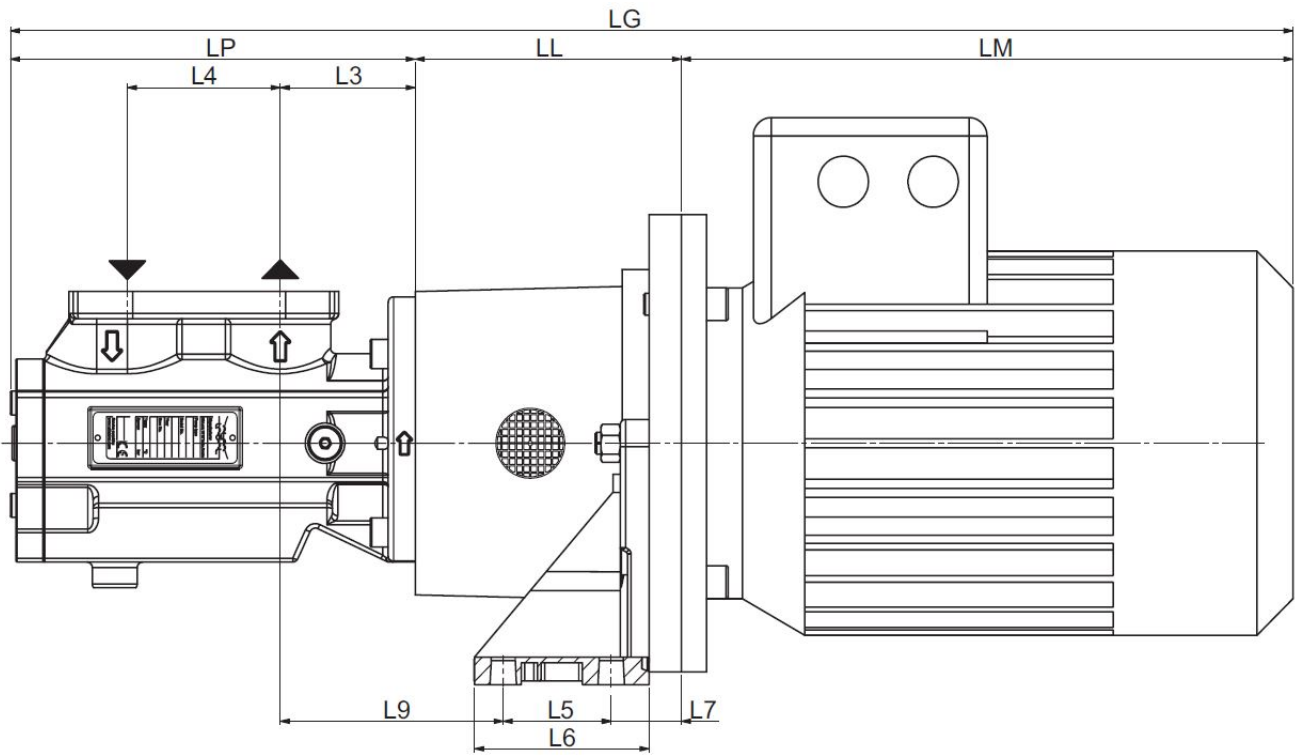

5.5 Capacity tables

Table 7: Capacity at 50 Hz, $\Delta p = 4$ bar

Size	Rotation speed	v_{max}^*	Motor	Delivery rate [l/min] at viscosity [mm ² /s]									
	[min ⁻¹]	[mm ² /s]	[kW]	13	30	40	60	100	180	380	460**	700**	1200**
ALP 15	2800	1600	4.00	26.3	27.1	27.4	27.7	28.0	28.5	28.5	28.5	28.6	28.7
	1400	2880	1.10	11.8	12.6	12.9	13.2	13.5	13.7	14.0	14.0	14.1	14.2
	900	3480	0.66	6.6	7.4	7.7	8.0	8.3	8.6	8.8	8.8	8.9	9.0
ALP 20	2800	1065	4.00	34.6	35.7	36.0	36.4	36.8	37.2	37.5	37.6	37.7	37.8
	1400	2410	1.10	15.5	16.6	16.9	17.3	17.7	18.1	18.4	18.5	18.6	18.7
	900	3130	0.66	8.7	9.8	10.1	10.5	10.9	11.3	11.6	11.6	11.8	11.9
ALP 30	2800	1140	4.00	55.9	57.2	57.6	58.0	58.5	58.9	59.3	59.4	59.5	59.6
	1400	2480	2.20	25.8	27.1	27.5	28.0	28.5	28.9	29.2	29.3	29.4	29.6
	900	3180	0.66	15.1	16.4	16.8	17.3	17.7	18.1	18.5	18.6	18.7	18.9
ALP 40	2800	625	4.00	74.5	76.2	76.7	77.3	78.0	78.5	79.0	79.1	79.3	79.5
	1400	1950	2.20	34.4	36.2	36.7	37.3	37.9	38.5	39.0	39.1	39.2	39.4
	900	2750	1.32	20.1	21.8	22.4	23.0	23.6	24.2	24.7	24.8	24.9	25.1
ALP 55	2800	855	5.50	102.3	104.5	105.2	106.0	106.8	107.5	108.1	108.2	108.5	108.7
	1400	2200	2.20	47.5	49.7	50.4	51.2	52.0	52.7	53.3	53.5	53.7	54.0
	900	2960	1.32	28.0	30.2	30.9	31.7	32.5	33.2	33.8	33.9	34.2	34.4
ALP 75	2800	440	5.50	132.3	134.9	135.7	136.6	137.6	138.4	139.1	139.3	139.6	139.9
	1400	1710	2.20	61.5	64.5	65.3	66.2	67.2	68.0	68.7	68.9	69.2	69.5
	900	2550	1.32	36.8	39.4	40.2	41.1	42.0	42.9	43.6	43.8	44.0	44.3
ALP 85	2800	300	5.50	147.7	150.4	151.2	152.2	153.1	154.0	154.7	154.9	155.2	155.5
	1400	1500	3.00	69.5	72.2	73.0	73.9	74.9	75.7	76.5	76.7	77.0	77.3
	900	2 60	1.32	41.5	44.2	45.0	46.0	47.0	47.8	48.6	48.7	49.0	49.3

Table 8: Capacity at 60 Hz, $\Delta p = 4$ bar

Size	Rotation speed	v_{max}^*	Motor	Delivery rate [l/min] at viscosity [mm ² /s]									
	[min ⁻¹]	[mm ² /s]	[kW]	13	30	40	60	100	180	380	460**	700**	1200**
ALP 15	3400	1210	4.80	32.5	33.3	33.6	33.9	34.2	34.5	34.7	34.8	34.9	34.9
	1700	2550	1.30	14.9	15.7	16.0	16.3	16.6	16.8	17.1	17.1	17.2	17.3
	1100	3240	0.65	8.7	9.5	9.8	10.1	10.4	10.6	10.9	10.9	11.0	11.1
ALP 20	3400	710	2.60	42.8	43.9	44.2	44.6	45.0	45.4	45.7	45.7	45.9	46.0
	1700	2050	1.30	19.6	20.7	21.0	21.4	21.8	22.2	22.5	22.5	22.7	22.8
	1100	2800	0.90	8.7	9.8	10.1	10.5	10.9	11.3	11.6	11.6	11.8	11.9
ALP 30	3400	780	4.80	68.8	70.1	70.5	70.9	71.4	71.8	72.2	72.2	72.4	72.5
	1700	2120	2.60	32.3	33.6	34.0	34.4	34.9	35.3	35.7	35.7	35.9	36.0
	1100	2890	0.90	19.4	20.7	21.1	21.5	22.0	22.4	22.8	22.9	23.0	23.2
ALP 40	3400	340	4.80	91.6	93.4	93.9	94.5	95.1	95.7	96.2	96.3	96.5	96.6
	1700	1550	2.60	43.0	44.7	45.3	45.9	46.5	47.0	47.5	47.6	47.8	48.0
	1100	2400	1.30	25.8	27.6	28.1	28.7	29.3	29.9	30.4	30.5	30.7	30.9
ALP 55	3400	530	6.60	125.7	128.0	128.6	129.4	130.2	130.9	131.6	131.7	131.9	132.2
	1700	1820	2.60	59.2	61.5	62.1	62.9	63.7	64.4	65.1	65.2	65.5	65.7
	1100	2650	1.80	35.8	38.0	38.7	39.5	40.3	41.0	41.6	41.7	42.0	42.2
ALP 75	3400	200	4.80	162.5	165.1	165.9	166.8	167.8	168.6	169.3	169.5	169.8	170.0
	1700	1330	3.60	77.0	79.6	80.4	81.3	82.3	83.1	83.8	84.0	84.3	84.6
	1100	2200	1.80	46.8	49.4	50.2	51.2	52.1	52.9	53.7	53.8	54.1	54.4
ALP 85	3400	105	4.80	181.2	183.9	184.7	185.7	186.6	187.5	188.3	188.4	188.7	189.0
	1700	1120	3.60	86.2	88.9	89.7	90.7	91.7	92.5	93.3	93.4	93.7	94.0
	1100	1980	1.80	52.7	55.4	56.2	57.2	58.1	59.0	59.8	59.9	60.2	60.5

* Max. possible viscosity without cavitation with a suction head of -4 mWC at sea level.

** Re-sizing of motor required.

5.6 Sound pressure levels

Guide values at 1 m distance, 1 450 min⁻¹, 8 bar.

Table 9: Sound pressure levels

Sound pressure level max. ± 3 [dB(A)]			
Size	15 - 20	30 - 40	55 - 85
Pump	56	59	65

5.7 Overflow valve

Table 10: Short-circuit pressure of the overflow valve

Size	Short-circuit pressure [bar] at rotation speed [min ⁻¹]							
	Overflow valve A				Overflow valve B			
	1450	1750	2900	3500	1450	1750	2900	3500
15 - 20	6.5	7.0	7.5	8.0	10.5	11.0	12.0	12.5
30 - 40	6.5	7.0	7.5	8.5	10.5	11.5	12.5	14.0
55 - 85	7.5	8.0	9.0	10.0	13.0	13.5	14.0	15.0

5.8 Materials

Table 11: Materials

	Material name	Material no.
Pump housing	EN-GJS-400-15	EN-JS1030
End cover	16MnCr5	1.7139
Screw set	35S20	1.0726

6 Function description

6.1 Structure

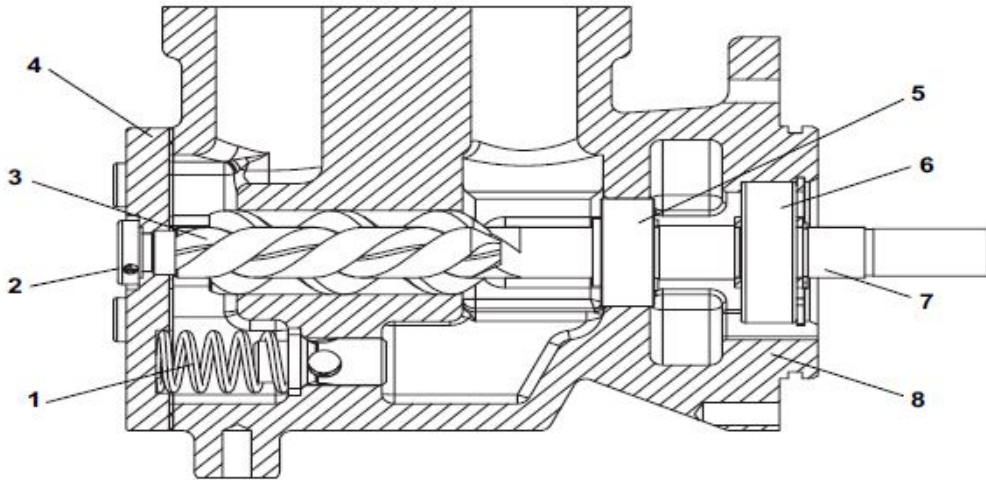

Figure 3: Structure of ALP pump

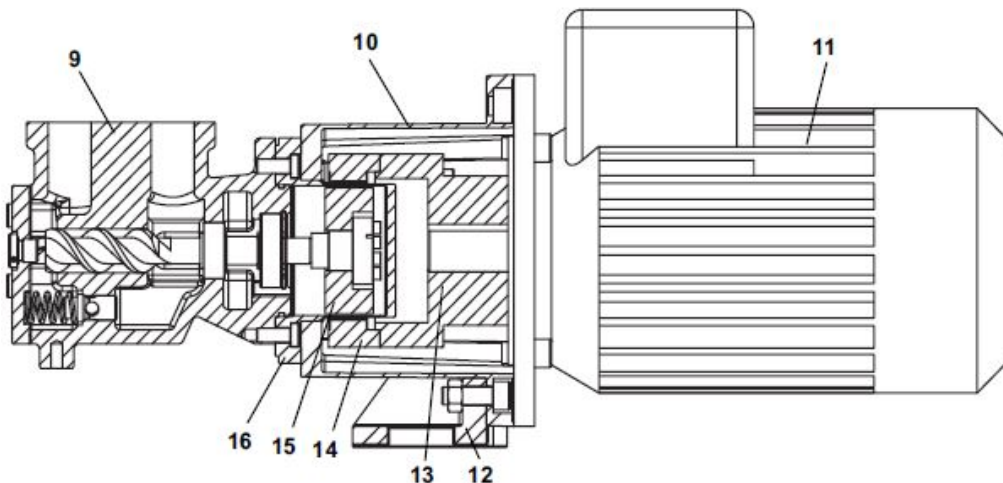

Figure 4: Structure of ALP pump with magnetic coupling and motor

- | | | | |
|-------------------|-----------------------|-----------------------|---------------------|
| 1. Overflow valve | 5. Balancing cylinder | 9. Pump | 13. Coupling hub |
| 2. Screw plug | 6. Ball bearing | 10. Pump bracket | 14. Outer rotor |
| 3. Idle screw | 7. Main screw | 11. Motor | 15. Inner rotor |
| 4. End cover | 8. Pump housing | 12. Pump bracket foot | 16. Containment can |

Screw pumps are rotating displacement pumps whose displacement effect results from the meshing of three rotating screws and the enclosing housing. The radial support of the screws is effected by the sliding contact in the housing which requires lubrication by the pumped liquid. Screw pumps are therefore not suitable for dry running and can only be used up to specific pressure and viscosity limits. Due to the narrow tolerances, pumping of suspended solids is not possible.

Axial support of the main screw is carried out by a deep-groove ball bearing. An internal overflow valve protects against excessive pressure that could cause housing parts to burst.

6.1.1 Standard direction of rotation

Clockwise, as seen from the drive; marked on the housing by two arrows.

Refer to [Structure](#) on page 25.

6.1.2 Flow direction

Marked on the housing by two arrows.

Refer to [Structure](#) on page 25.

6.2 Magnetic coupling

The shaft end of the pump is enclosed by a containment can, that is connected air-tight with the motor-side flange of the pump. Special rotors equipped with powerful magnets are used to transfer the torque from the motor to the pump. The inner rotor is fixed at the shaft end and driven from the outer rotor, which in turn is fixed to the shaft of the motor. The torque is thus transferred contact-free by means of magnetic field between the outer and inner rotor.

The pressure discharge of the containment can approximately corresponds to the pressure on the suction side of the pump.

6.3 Overflow valve

The integrated overflow valve prevents very high pressures which can result in housing parts bursting. The valve is purely there as a safety element and should not be used for control or regulation such as maintaining pressure. Circulation through the overflow valve for too long heats the pump to excess. This reduces viscosity and can ultimately lead to pump failure. Two variants of the overflow valve are available.

The valve spring is pretensioned to the respective opening pressure.

Table 12: Pretension of the valve spring

	Overflow valve A	Overflow valve B
Pretension Δp [bar]	$6 \pm 10 \%$	$10 \pm 10 \%$

Short-circuit pressure of the overflow valve: Refer to [Overflow valve](#) on page 24.

7 Transportation, Storage and Disposal

7.1 Unpacking and checking the state of delivery



1. Upon delivery unpack the pump/pump unit and check for transport damage.
2. Report any transport damage immediately to the manufacturer.
3. Dispose of packing materials in accordance with the locally applicable regulations.

7.2 Lifting the pump/pump unit

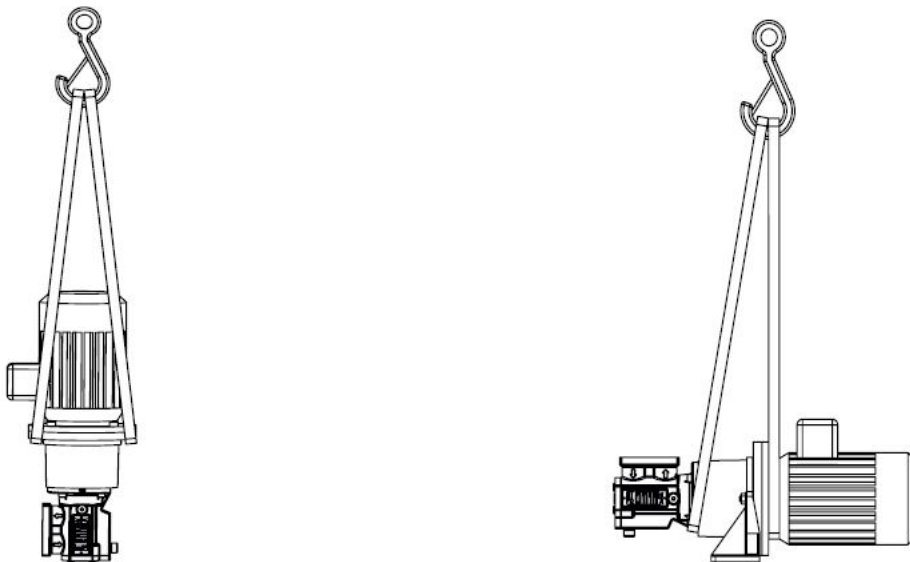

Figure 5: Attachment of hoisting equipment - schematic diagrams



Risk of injury and/or damage to equipment should the pump/pump unit fall.

- Use intact and correctly dimensioned hoisting equipment suitable for the weight to be lifted.
- Choose the attachment points of the hoisting equipment according to the centre of gravity and weight distribution.
- Always use at least two slings.
- For vertical transport: secure motor additionally against tilting.
- Do not stand under raised loads.



1. Pump: Depending on the locally applicable regulations, the pump can be transported either manually or by using suitable hoisting equipment.
2. Pump unit: Attach the hoisting equipment to the pump unit, and lift the pump unit.

7.3 Storage

During the test run, the internal components of the pump are wetted with test oil, which has a preservative effect. The pipe connections are fitted with protective covers. The external components of the pump are preserved with a single-coat PU based two-component paint. The preservative applied at the factory will protect the pump for about six weeks, if it is stored in a dry and clean location. The manufacturer offers a long-term preservation for storage times of up to 60 months. With long term conservation the pump is additionally packed in hermetically sealing anti-corrosion paper.

7.4 Preservation

Preservation has to be carried out in the following cases:

- **For standard delivery** : for storage periods exceeding six weeks and in case of adverse storage conditions such as high humidity, salty air, etc.
- **For delivery with long-term preservation**: If the packaging has been opened or damaged.

Preserving the internal surfaces of the pump



1. Close the suction connection of the pump with a blind flange.
2. Pour noncorrosive, resin-free oil into the pressure connection until it reaches approx. 2 cm under the pressure flange, while slowly turning the main screw against the direction of rotation.
3. Close the pressure connection of the pump with a blind flange.

After about 6 months storage check the oil level in the pump and top up if necessary

Preserving the external surfaces of the pump



Recommendations:

- Preservative (e.g. Castrol Rustilo DWX 33).
 - Paint or spray the preservative onto all plain and unpainted parts.

At intervals of about six months, check the preservative effect and if necessary repeat preservation.

NOTE

Store the preserved pump in a cool and dry place and do not expose it to direct sunlight.

7.4.1 Removing the preservation

Recommendations:

- Solvent
- Steam-jet cleaning device with wax-dissolving additives



Risk of injury through emitted preservative oil.

- Wear protective clothing during all the work.
- Remove the blind flange with caution to relieve any pressure inside the pump.
- Collect the emitted oil safely and dispose of it in an environmentally compatible manner.



1. Clean the outside of the pump with solvents, if necessary using a steam-jet cleaning device.
2. Remove the blind flange on the pressure side.
3. Drain the pump, collecting the preservative oil in a suitable vessel.
4. Remove the blind flange on the suction side.
5. To remove the residual oil, rinse the pump with the pumped liquid.

7.4.2 Disposing of the pump

Recommendations:

- Solvents or industrial cleaners suitable for the pumped liquid.



Danger of poisoning and damage to the environment from the pumped liquid.

- Wear protective clothing during all the work.
- Collect the discharging pumped liquid and oil and dispose of it in accordance with the locally applicable regulations.
- Neutralize any residues of the pumped liquid.



1. Disassemble the pump.
2. Clean residues of the pumped liquid from the individual parts.
3. Separate sealing elements made of elastomers and ceramics (SiC) from the pump and dispose of them in the residual waste.
4. Recycle metal parts.

8 Installation, removal and connection

8.1 Safety instruction on installation, removal and connection



NOTE

The following safety instruction must be observed during installation, removal and connection work.

- There is a risk of death for people with pacemakers
 - Under no circumstances may persons with pacemakers perform installation, removal or connection work.

8.2 Installation

NOTE

Observe the following instructions.

- When selecting the location take the operating limits, NPSH values and ambient conditions into account; refer to [Technical data](#) on page 17.
- The function, safety and service life may not be impaired by humidity, temperature influences or explosive atmospheres.
- During the installation ensure that all the parts of the pump can be accessed easily and that the maintenance work can be carried out easily.

8.3 Installing the pump

Screw pumps can be operated in any installation position. However, we recommend that the pump should not be mounted above the motor since pumped liquid could enter the motor should a leak occur.

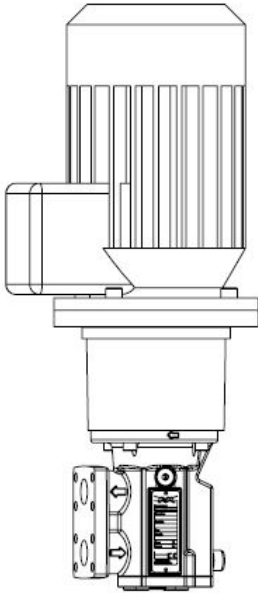

Figure 6: Model ALP vertical mounting

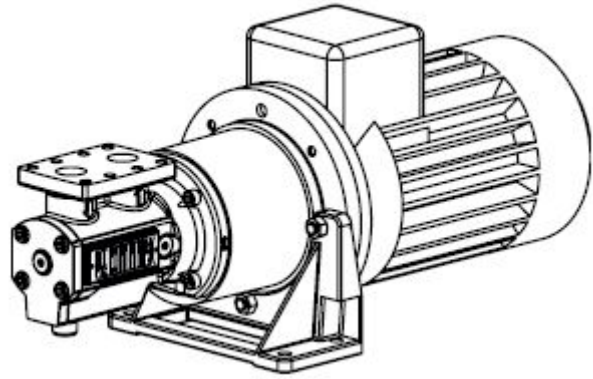

Figure 7: Model ALP Horizontal mounting

Prerequisite:

- The pump connections are to be protected against soiling, for example by using the protective covers mounted in the factory.



CAUTION

Leaking pumped liquid can damage the motor.

- Do not mount the pump above the motor.



CAUTION

Damage to the pump and piping through insufficient fastening.

- Only fasten the pump on a stable load bearing surface.
- Ensure that the fastening elements are tightened sufficiently.



1. Bring the pump into position. Ensure that the flow direction that is marked by arrows on the flanges is correct.
2. Fasten the pump with fastening elements securely to the mounting surface.

8.4 Protect the pump against soiling



CAUTION

Damage through impurities in the pipe system.

- During welding work attach protective covers to the connecting flanges.
- Ensure when welding that welding beads and abrasive dust cannot get into the pipe system and the pump.
- After the connecting work carefully clean the pipe system; refer to

8.4.1 Connecting the pump to the pipe system

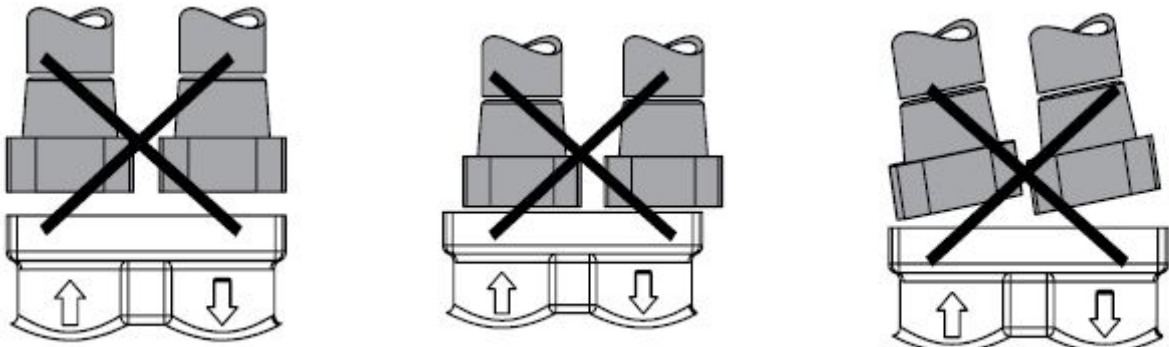

Figure 8: Wrong installation

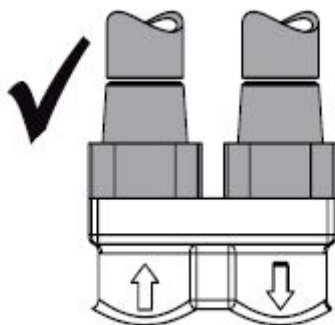

Figure 9: Correct installation

CAUTION

Danger of damage to the device or impaired functionality through mechanical stresses.

- Ensure that the pump mounting on the pipe system is free of mechanical stress.



1. Turn the pump shaft or the fan impeller of the motor. This tests that the pump runs smoothly.
If the pump cannot be turned by hand, remedy the fault before installing the pump.
2. During welding work attach protective covers to the connecting flanges.
3. Place the piping in position and support the weight of the piping.
4. Check the clearance and the angular, vertical and linear offset, adjusting where necessary.
If the screws tighten easily, this is a sure sign that the installation is stress-free.
5. Tighten the connecting screws crosswise with torque.

8.4.2 Connecting the motor



Risk of death resulting from electric shock.

- The motor may only be connected by an authorized electrician.
- Ensure that the power supply is disconnected.
- Earth the pump carefully.



1. Observe the operating instructions of the motor.
2. Ensure that the operating data on the rating plate of the motor agrees with the operating data of the pump and with the local power supply.
3. Connect the motor in accordance with the circuit diagram in the motor terminal box.

8.5 Removing the pump

Recommendations:

- Vessels for leaking pumped liquid



Risk of death resulting from electric shock.

- Ensure that the power supply is disconnected.
- The motor may only be separated from the power supply by an authorized electrician.



Risk of injury through emitted hot, poisonous or corrosive pumped liquid.

- Wear protective clothing during all the work.
- Before carrying out work let the pump cool down to the ambient temperature.
- Ensure that the pump is depressurized.
- Collect the pumped liquid safely and dispose of it in an environmentally compatible manner.



1. Disconnect the motors from the power supply and secure them against being switched back on.
2. Close the pressure-side and suction-side shut-off devices.
3. Empty the pump at the lower point using the draining plug. Collect the emitted pumped liquid in a suitable vessel
4. Loosen the connecting flanges.
5. Loosen the fastening of the pump unit on the mounting surface and dismantle the motor and pump bracket.

9 Operation

9.1 Commissioning



The following safety instruction must be observed during commissioning.

- There is a risk of death for people with pacemakers
 - Under no circumstances may persons with pacemakers perform commissioning work.



The following instructions must always be observed.

- 1 The pump may only be commissioned by authorized qualified personnel.



- 2 Wear protective clothing during all the work.



9.2 Cleaning the pipe system

To protect the pump against soiling the complete pipe system has to be cleaned carefully before initial commissioning of the pump. If the pipe system is to be rinsed using the pump, an additional commissioning filter has to be installed before the pump.

Mesh width of the commissioning filter:

- 0.025 mm



Damage to the pump through additional pressure loss in the commissioning filter.

- 1 Calculate the flow resistance and determine the remaining pump intake.
- 2 Monitor the suction-side pressure.
- 3 Check and clean the commissioning filter regularly.
- 4 Recommended rinsing duration with commissioning filter: 50 -100 hours.



9.3 Filling the pump

There are two possible ways to fill the pump:

1. Pumped liquid already exists at the suction or pressure side: filling via suction or pressure connection.

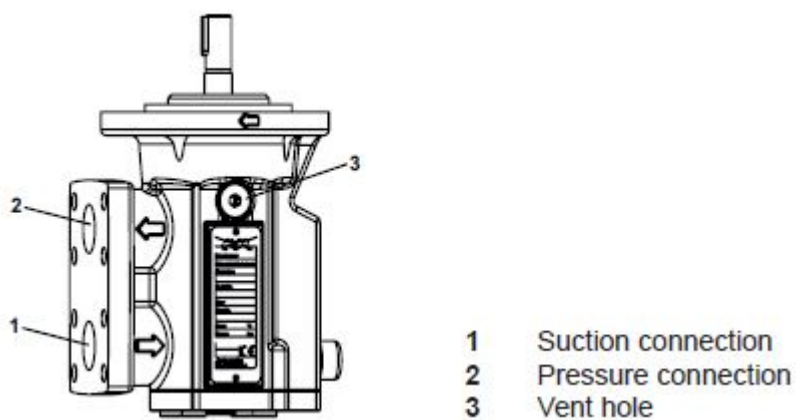

Figure 10: Filling the pump

2. There is no pumped liquid at the suction or pressure side: filling via the vent hole.

9.4 Filling the pump via the suction or pressure connection



Danger of injury or poisoning through dangerous pumped liquids.

Collect the emitted pumped liquid safely and dispose of it in an environmentally compatible manner.

- 1 Open the vent hole **3** so that the air can escape during the filling process.
- 2 Open the suction- or pressure-side shut-off device and fill the pump via the suction or pressure connection until pumped liquid is emitted at the vent hole.
- 3 During the filling process turn the pump shaft or the fan impeller of the motor by hand to speed up the filling process:
 - Filling via suction connection **1**: Turn the pump shaft in the direction of rotation of the motor.
 - Filling via pressure connection **2**: Turn the pump shaft against the direction of rotation of the motor.
- 4 Close the vent hole.



9.5 Checking direction of rotation

The direction of rotation and the flow direction are indicated by arrows on the pump. The direction of rotation of the motor gives the direction of rotation of the pump. That is to say, the fan impeller of the motor must rotate in the direction in which the arrow on the pump is pointing to indicate direction of rotation.

Standard direction of rotation: clockwise (as seen from the drive)

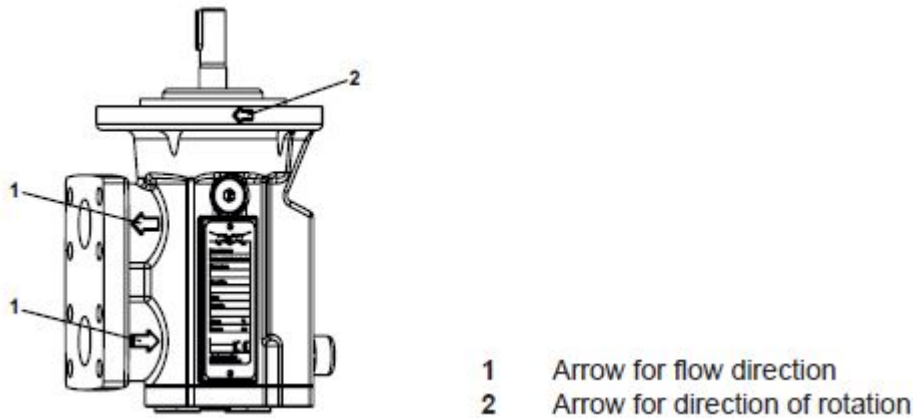

Figure 11: Identifying direction of rotation and flow direction

CAUTION

Dry running can damage pump equipment.

- Ensure that the pump is filled properly.
- Switch the pump on for a maximum of 1 second and then off again immediately.

- 1 Switch on the power supply and then turn it off again immediately.



- 2 Compare the direction of rotation of the fan impeller with the arrow indicating direction of rotation on the pump flange.

- 3 If the directions do not match, swap over two electrical connection phases. Repeat Steps 1 and 2.

9.6 Commissioning the pump

Prerequisites:

- Pump set up and mounted correctly.
- Motor connected correctly.
- Pipe system is free of contamination.
- Commissioning filter mounted, if the pipe system is to be cleaned with the pump.
- Pump is filled.
- Any stop cocks in the suction and pressure line opened.



WARNING

Danger of injury through emitted pumped liquid.

- Wear protective clothing during all the work.
- Ensure that all the connections are connected sealingly.



CAUTION

Dry running can damage pump equipment.

- Ensure that the pump is filled properly.
- If the pump does not deliver after 10 - 15 seconds, abort commissioning.

- 1 Ensure that the pump is filled. In case of doubt pre-lubricate the pump by pouring in liquid via the vent hole; refer to [Filling the pump](#) on page 41.
- 2 Switch on the pump.
The pump will deliver when the pressure on the pressure side of the pump rises or a system-side flow indicator triggers.
- 3 If the pump does not deliver after 10 - 15 seconds of operation, abort initial commissioning, establish the cause of the fault and only then continue the commissioning procedure. Follow the instructions in the fault table.
- 4 Run the pump for a few minutes to allow the pipe system to vent fully.
The pipe system is fully vented when there is a smooth operating noise and a pressure gauge on the pressure side of the pump shows no more fluctuations.

9.7 Taking pump out of operation

WARNING

Risk of injury or poisoning through emitted pumped liquid.

- Wear protective clothing during all the work.
- Collect the emitted pumped liquid safely and dispose of it in an environmentally compatible manner.



- Carry out the following measures during shutdowns:

Table 13: Measures for operation interruption

Pump is	Measure
• Shut down for longer period	Depending on the pumped liquid.
• Drained	Close the pressure-side and suction-side stopcocks.
• Dismantled	Disconnect the motors from the power supply and secure them against being switched back on.
• Stored	Observe measures for storing & preservation; refer to Storage on page 28 and refer to Preservation on page 29.

Table 14: Measures depending on behaviour of the pumped liquid

Behaviour of the pumped liquid	Duration of the shut down	
	Short	Long
• Sediment solids	– Rinse the pump.	– Rinse the pump.
• Congealed/frozen • No corrosive burden	– Heat or drain the pump.	– Drain the pump.
• Congealed/frozen • Corrosive burden	– Heat or drain the pump.	– Drain the pump. – Preserve the pump.
• Remains liquid • No corrosive burden	-	-
• Remains liquid • Corrosive burden	-	– Drain the pump. – Preserve the pump.



- Drain the pump via the pressure and suction line and vent screw.

9.8 Recommissioning the pump



Carry out all the steps as for the commissioning process. Refer to [Commissioning](#) on page 39.

10 Maintenance

10.1 Safety instructions on maintenance and repairs



 **DANGER**

There is a risk of death for people with pacemakers.

The following safety instructions must be observed during all work:

- Under no circumstances may persons with pacemakers perform maintenance or repair work.
- All the work may only be carried out by authorized qualified personnel.
- Wear protective clothing during all the work.
- Switch off the motor and secure it against being switched back on.
- Before beginning the work let the pump/ the pump unit cool down to the ambient temperature and remove it from the pipe system.
- Ensure that the pump is depressurized.
- Collect the emitted pumped liquid safely and dispose of it in an environmentally compatible manner.

10.2 Required maintenance

The service life of the pump depends to a great extent on the operating conditions. If the operating limits are observed, refer to *Technical data* on page 17; the pump has a service life of many years.

Signs of progressive wear of individual pump elements:



Table 15: Check table for required maintenance

Finding	Cause	Remedy
Increased running noises.	Incipient damage to bearing.	Replace the bearing.
Reduction in the flow rate or pressure under constant operating conditions.	Advanced wear of screws and housing.	Replace the pump.



1. Check the pump visually and acoustically every four weeks.
2. Check for signs of wear as listed in the table above and eliminate the cause.

10.3 Magnetic coupling

The shaft end of the pump is enclosed by a containment can, that is connected air-tight with the motor-side flange of the pump. Special rotors equipped with powerful magnets are used to transfer the torque from the motor to the pump. The inner rotor is fixed at the shaft end and driven from the outer rotor, which in turn is fixed to the shaft of the motor. The torque is thus transferred contact-free by means of magnetic field between the outer and inner rotor.

The pressure discharge of the containment can approximately corresponds to the pressure on the suction side of the pump.

10.4 Ball bearing

The ball bearings used are lubricated by the pumped liquid. Maintenance is therefore not required.

We recommend renewing the ball bearings every two years.

10.5 Replacing the magnetic coupling

Removing the magnetic coupling

10.5.1 Dismantling the outer rotor

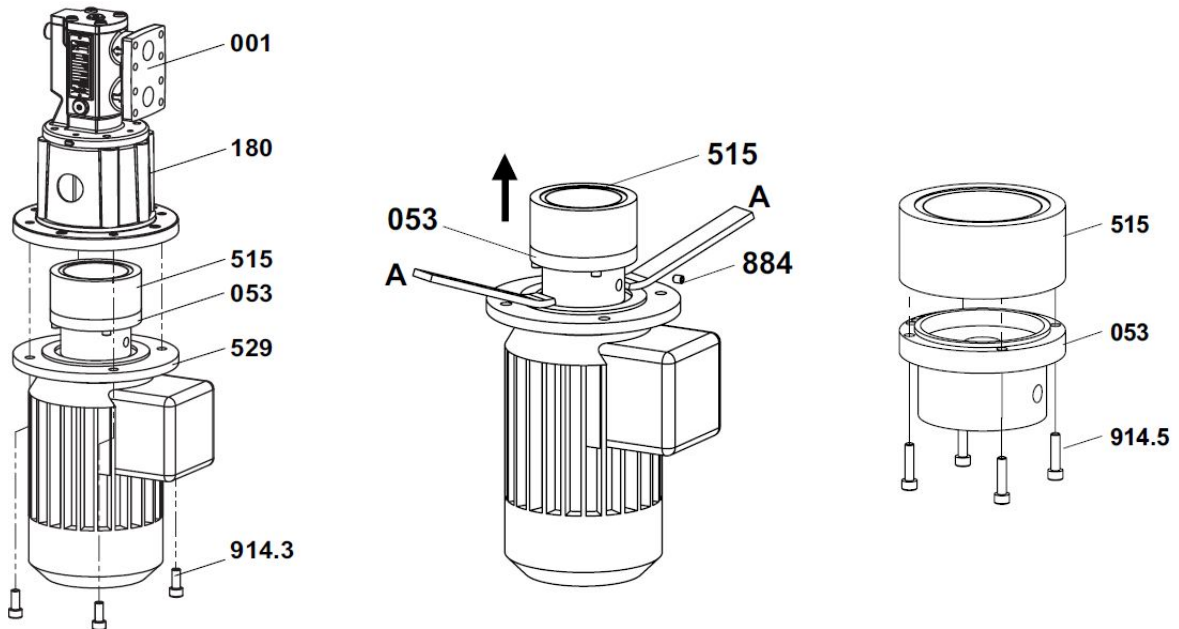

Figure 12: Outer rotor dismantling

Ref.	Description	Ref.	Description	Ref.	Description
001	Pump	515	Outer rotor	914.3	Socket screw
053	Coupling hub	529	Motor	914.5	Socket screw
180	Pump bracket	884	Threaded pin	A	Mounting lever

Recommendations:

- Wrench
- Mounting lever



Risk of injury and/or damage to equipment should the pump/pump unit fall.

- Lift large pumps/pump units using the crane
- Do not stand under raised loads.



- 1 Before dismantling close the suction and pressure connection of the pump with protective covers .
- 2 Loosen the connecting screws **914.3** between the motor **529** and pump bracket **180** and lift the pump with pump bracket from the motor.

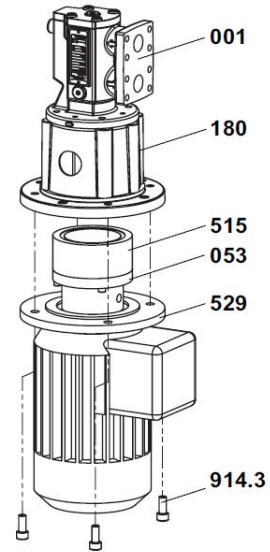

- 3 Loosen the threaded pin **884**. Pull the coupling hub **053** and outer rotor **515** off from the motor shaft using mounting levers **A**

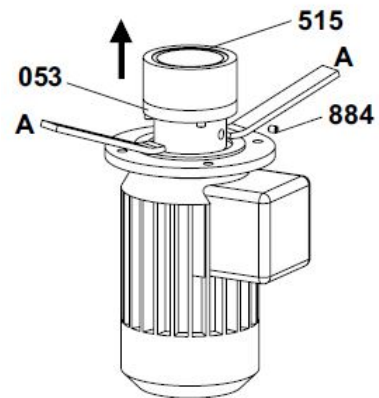

- 4 Loosen the socket screws **914.5** between the coupling hub **053** and the outer rotor **515** .

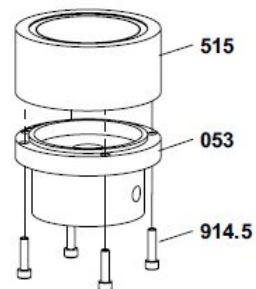

10.5.2 Dismantling the inner rotor

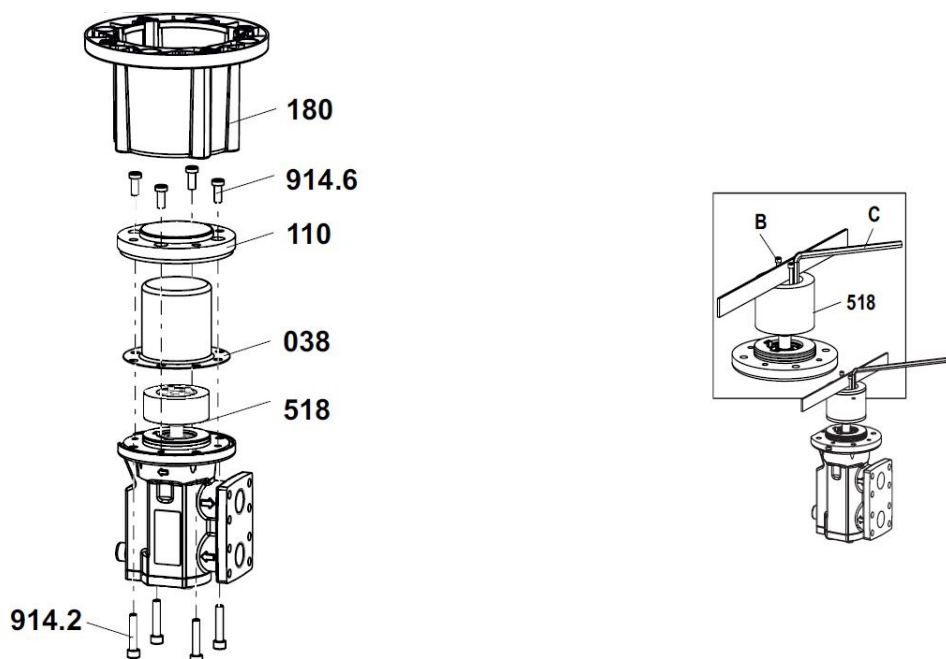

Figure 13: Inner motor dismantling

Ref.	Description	Ref.	Description	Ref.	Description
038	Containment can	518	Inner rotor	B	Anti-rotation screw
110	Centring flange	914.2	Socket screw	C	Allen key
180	Pump bracket	914.6	Socket screw		

Recommendations:

- Anti-rotation screw
- Allen key



- 1 Loosen the socket screws **914.2** between the pump and pump bracket **180** and remove the pump bracket.

- 2 Loosen the socket screws **914.6** between the centring flange **110** and pump.
Remove the containment can.

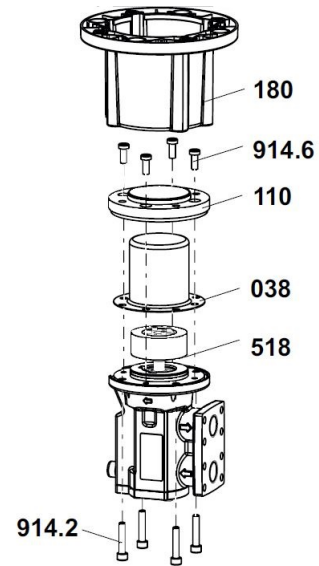

- 3 To replace the inner rotor **518**, insert two anti-rotation screws **B** into the empty threaded holes of the tensioning element to prevent rotation.
Then loosen the screws of the tensioning element and take the inner rotor off the shaft.

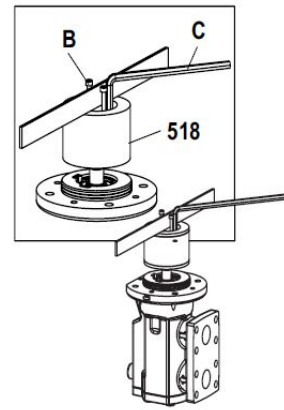

10.6 Installing the magnetic coupling

10.6.1 Mounting the inner rotor

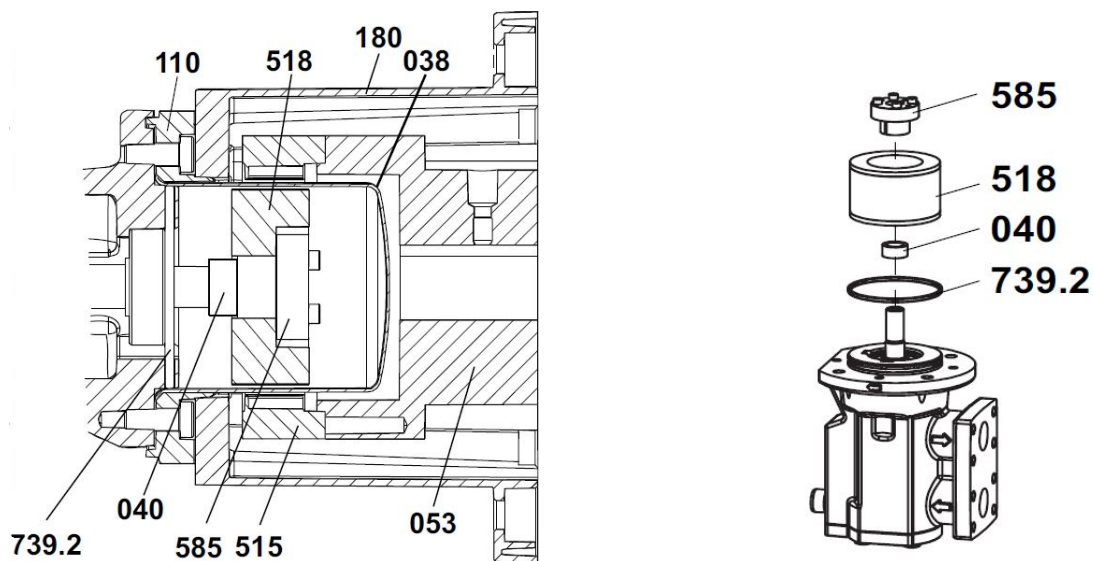
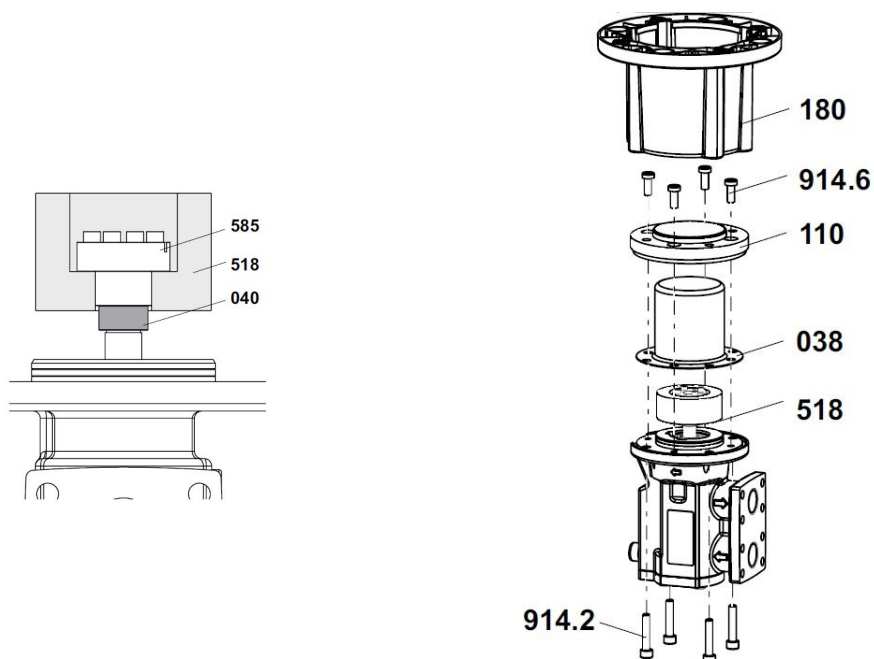

Figure 14: Sectional view magnetic coupling



Ref.	Description	Ref.	Description	Ref.	Description
038	Containment can	180	Pump bracket	739.2	O-ring
040	Distance sleeve	518	Inner rotor	914.2	Socket screws
110	Centring flange	585	Tensioning element	914.6	Socket screws



- 1 Carefully clean the sealing surfaces. Clean and slightly grease the O-ring. Insert the O-ring **739.2** and slide the distance sleeve **040** onto the pump shaft.

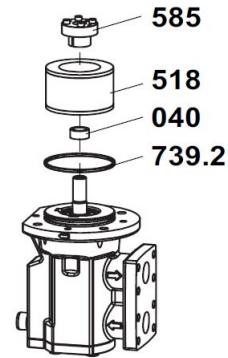

- 2 Clean the contact surfaces of the inner rotor **518** carefully. Oil the tensioning element **585** slightly.

! NOTE

Use only oil without molybdenum sulphide additive, eg.: Multifunctional spray WD-40 .

- 3 Turn out the screws of the tensioning element a few turns by hand. Insert the tensioning element in the inner rotor.

- 4 Place the inner rotor with pre-mounted tensioning element on the pump shaft and tighten the screws of the tensioning element crosswise by hand.

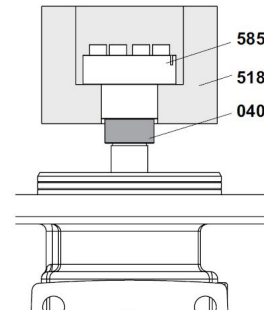

- 5 Check the position of the tensioning element: the tensioning element has to lie on the distance sleeve and inner rotor. Otherwise loosen the screws again and re-align the tensioning element.

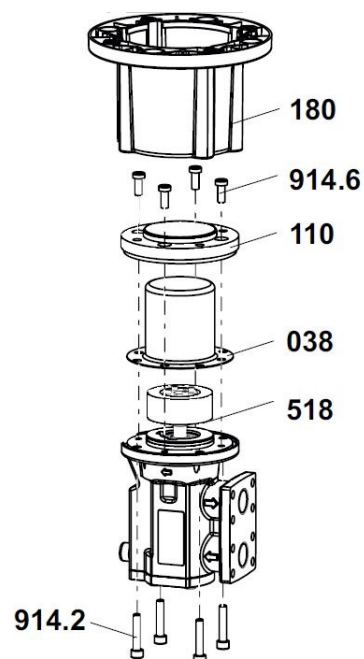

- 6 If the position is correct, first tighten the screws of the tensioning element with half the tightening torque crosswise. Subsequently tighten them several times crosswise with the **full** tightening torque until no screw can be turned any further.

! NOTE

The screws are only tightened correctly when they can no longer be turned while being tightened with the full torque.

- 7 Press the containment can **038** with the centring flange **110** onto the pump flange and tighten the connecting screws **914.6**,

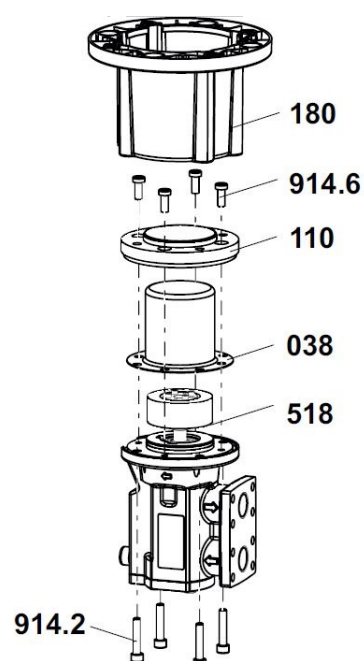

- 8 Place the pump bracket **180** on the pump and tighten the socket screws **914.2** .
-

10.6.2 Mounting the outer rotor

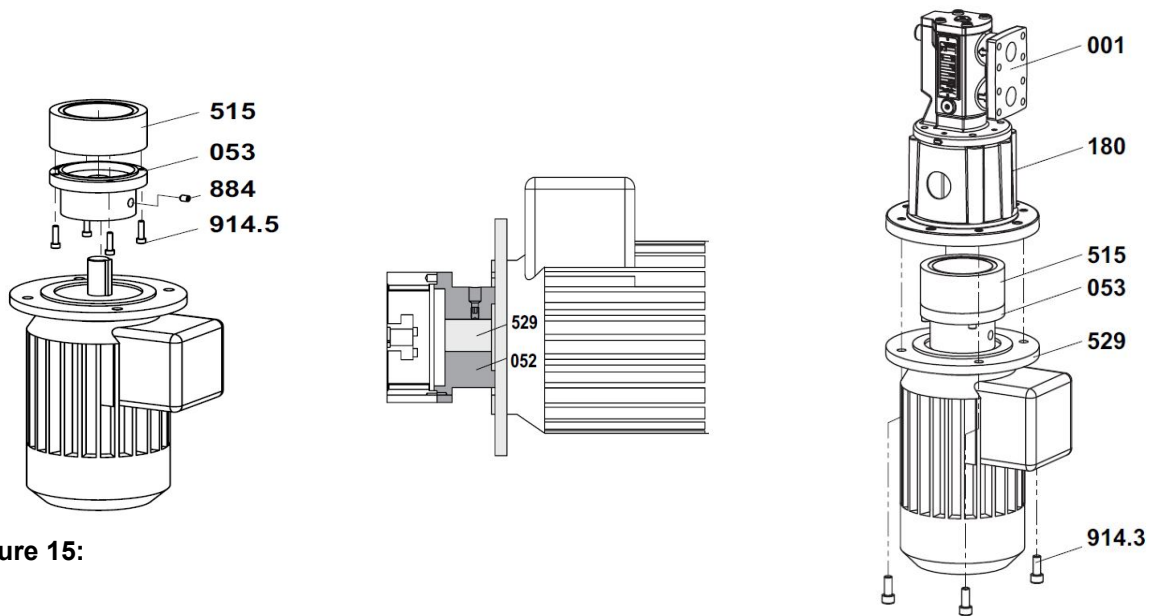
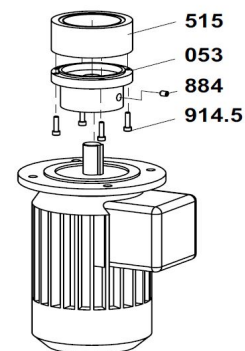

Figure 15:

Ref.	Description	Ref.	Description	Ref.	Description
001	Pump	515	Outer rotor	914.5	Socket screw
053	Coupling hub	529	Motor	914.3	Socket screw
180	Pump bracket	884	Threaded pin		



- 1 Carefully clean the outer rotor **515** with compressed air. Tighten the connecting screws **914.5** of the outer rotor and coupling hub **053** with torque.
- 2 Clean the shaft end of the motor and apply lubricant.
- 3 Place the coupling hub with outer rotor onto the shaft of the motor.
Heating up to approx. 80 °C facilitates mounting.
Tighten the threaded pin **884**.



- 4 The shaft end of the motor must be flush with the front surface of the coupling hub.

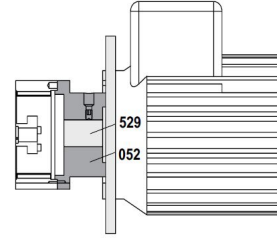

- 5 Place the pump with pump bracket on the motor.
Do not use force and ensure that the outer rotor does not strike the containment can.

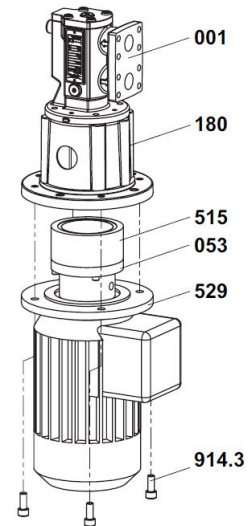

- 6 Tighten the connecting screws **914.3** of the motor and pump bracket.
Do not remove the protective covers until just before reconnecting the pump to the pipe system.

10.7 Replacing the ball bearing

10.7.1 Removing the ball bearing

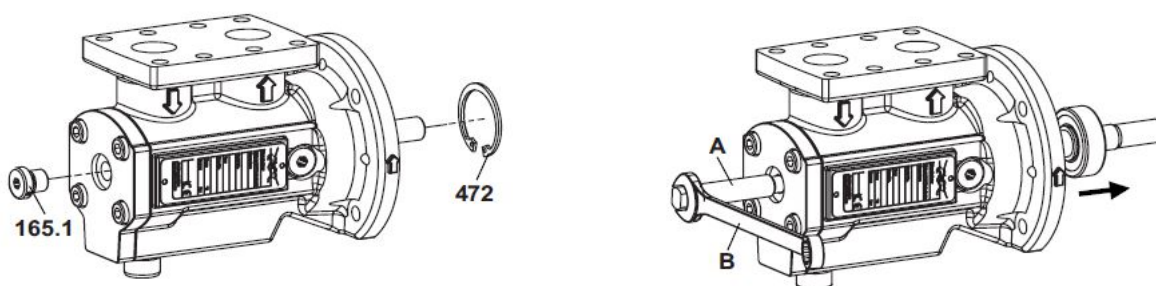
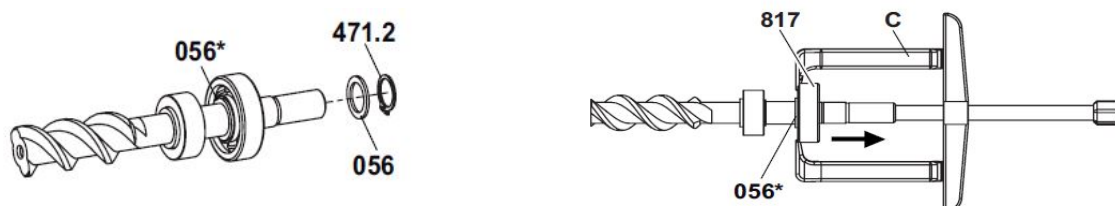

Figure 16:



Ref.	Description	Ref.	Description	Ref.	Description
056(*)	Supporting ring	472	Circlip	A	Disassembly tool
165.1	Screw plug	817	Ball bearing	B	Open-end wrench
471.2	Circlip	868*	Supporting ring	C	Extractor

* Only for sizes 100 - 115.

Recommendations:

- Disassembly tool
- Open-end wrench
- Extractor



1 Remove the circlip **472** and screw plug **165.1**.

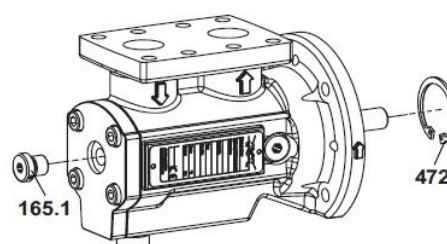

- 2 Screw in the disassembly tool **A** by using the open-end wrench **B**.
The main screw will be pressed out of the pump housing. Remove the main screw from the pump housing.

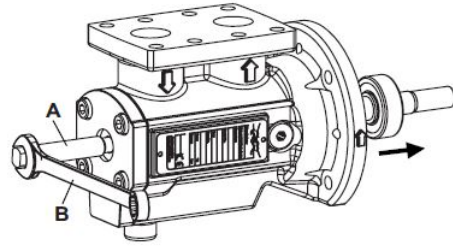

- 3 Remove the circlip **471.2** and supporting ring **056**.

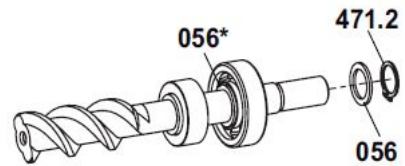

- 4 Pull the ball bearing **817** from the main screw using a suitable extractor **C**.

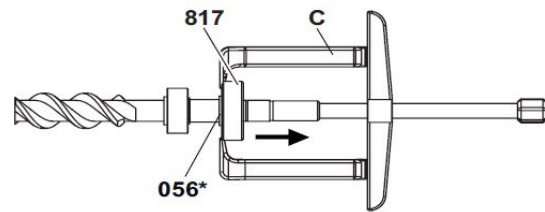

10.7.2 Installing the ball bearing

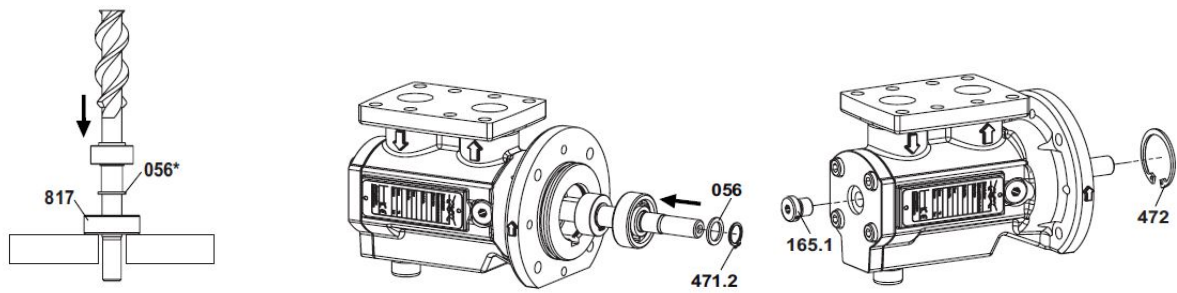
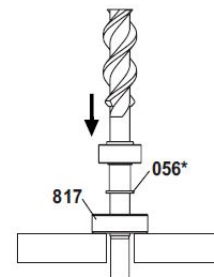

Figure 17: Ball bearing installation

Ref.	Description	Ref.	Description
056	Supporting ring	472	Circlip
165.1	Screw plug	817	Ball bearing
471	Circlip	868*	Supporting ring

* Only for sizes 100 - 115.

- 1 Clean the fitting surfaces and the main screw. Grease the main screw slightly.
- 2 Push the supporting ring 868* onto the main screw, press the ball bearing 817 onto the main screw.



- 3 Mount the supporting ring 056 and circlip 471. Slide the main screw with premounted ball bearing into the pump housing until the main screw engages into the idle screws. In doing so turn the main screw.

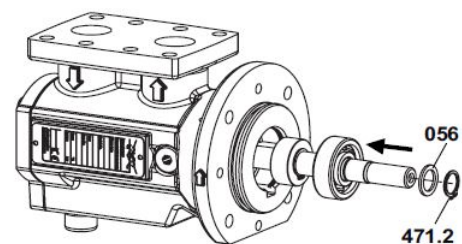

- 4 Mount the screw plug 165.1 and circlip 472.

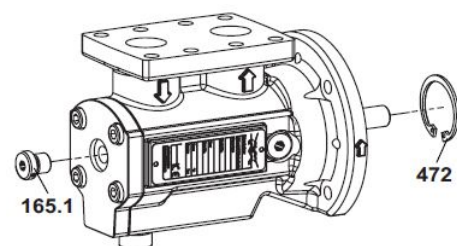

11 Troubleshooting

11.1 Possible faults

Faults can have different causes. The following tables list the symptoms of a fault, the possible causes and measures for elimination.



Fault	Cause/Remedy
• No pump suction	1, 2, 3, 4, 5, 6, 7, 8, 28
• Delivery rate too low	2, 3, 4, 9, 10, 11, 12, 13, 14, 15, 16, 17
• Pump runs noisily	2, 3, 4, 6, 10, 11, 13, 15, 18, 19, 20, 21
• Motor overload	9, 11, 14, 21, 22
• Uneven delivery rate	2, 3, 4, 6, 11, 13, 15, 16
• Magnetic coupling leaks	24, 25
• Pump has seized up	26, 27

11.2 Troubleshooting



Table 16: Fault table

No.	Cause	Remedy
1	Pump suction pipe closed.	- Check shut-off devices in the suction pipe and open them, if necessary.
2	Suction valve or pipe obstructed.	- Check the suction valve and pipe for clear passage.
3	Suction pipe or shaft seal leaks.	- Check suction pipe or shaft seal for leaks. Pay particular attention to leakage at valves and connection points. If necessary, replace parts.
4	Suction head too high.	- Reduce difference of level -or- - Reduce pipe length -or - Increase pipe diameter -or - Heat the liquid to reduce viscosity -or - Install suction filter with greater mesh width. Ensure that the permissible mesh width is not exceeded; refer to <i>Cleaning the pipe system</i> on page 40.
5	Level of liquid in the intake container too low.	- Top up the pumped liquid.
6	Dirty filter/strainer.	- Clean the filter/strainer.
7	Pump intake capacity reduced by inadequate wetting.	- Fill pump with liquid.
8	Incorrect pump direction of rotation.	- Carry out the electrical connection so that the direction of pump rotation matches that of the arrow on the flange cover.
9	Differential pressure too high.	- Check the system and reduce the differential pressure.
10	Magnetic coupling broken off.	- Stop the pump immediately and restart it. - Avoid excessive differential pressures. - At repeated occurrence check whether pump has seized up.
11	Viscosity of the pumped liquid too high.	- Increase the temperature of the liquid -or - Reduce the rotation speed.
12	Viscosity of the pumped liquid too low.	- Reduce the temperature of the liquid -or - Increase the rotation speed.
13	Airlock or gas in the liquid.	- Test the pipe system for ingress of air and replace parts if necessary. - Reduce the suction head -or - Increase the feed pressure.
14	Motor running at wrong voltage or frequency.	- Ensure that the motor voltage and frequency match the operating voltage. - Compare the rotation speed of the motor with the pump rating plate. If the data does not match, adjust the rotation speed of the motor.
15	Overflow valve opens during normal operation.	- Set opening pressure above value of operating pressure.
16	Overflow valve leaks.	- Clean the overflow valve and if necessary, reset.

No.	Cause	Remedy
17	Advanced wear of rotating pump components.	- Check screw set and housing and replace if necessary.
18	Pump distorted.	- Support the weight of the piping. - Loosen pipe connections and mount stress-free; refer to Installation on page 33.
19	Resonance in the system.	- Provide a flexible bearing arrangement -or - Make the connections with hoses.
20	Speed of flow in suction or pressure line too high.	- Set the flow speed in the suction line so that it does not exceed 1 m/s. - Set the flow speed in the pressure line so that it does not exceed 3 m/s.
21	Ball bearing damaged.	- Replace the ball bearing; refer to Replacing the ball bearing on page 59.
22	Lack of lubrication or foreign bodies have caused superficial damage to rotating pump components.	- Check the screw set and the housing. If necessary, replace pump with free shaft end.
23	Thermal or chemical loading of elastomer seals exceeded.	- Check the maximum operating temperature. - Check the resistance of the elastomers with regard to the pumped liquid.
24	Containment can damaged by abrasive liquids.	- Replace the containment can and O-ring; refer to Replacing the magnetic coupling on page 49.
25	Foreign bodies in the pump.	- Dismantle the pump and clean it. - Smooth the superficial damage to the housing and the rotating parts with an oilstone. If necessary, replace the pump with free shaft end.
26	Dry running can damage the pump.	- Dismantle the pump and clean it. - Smooth the superficial damage to the housing and the rotating parts with an oilstone. If necessary, replace pump with free shaft end. - When resuming operation, take action to prevent dry running; refer to Recommissioning the pump on page 46.
27	Pump does not vent.	- Vent the pressure line at the highest point.

12 Spare Parts

12.1 ALP magnetic coupling spare parts

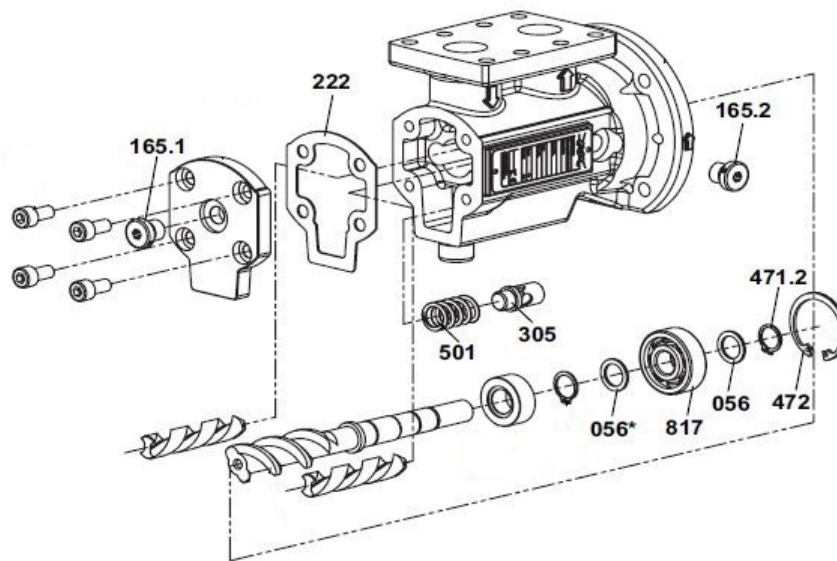
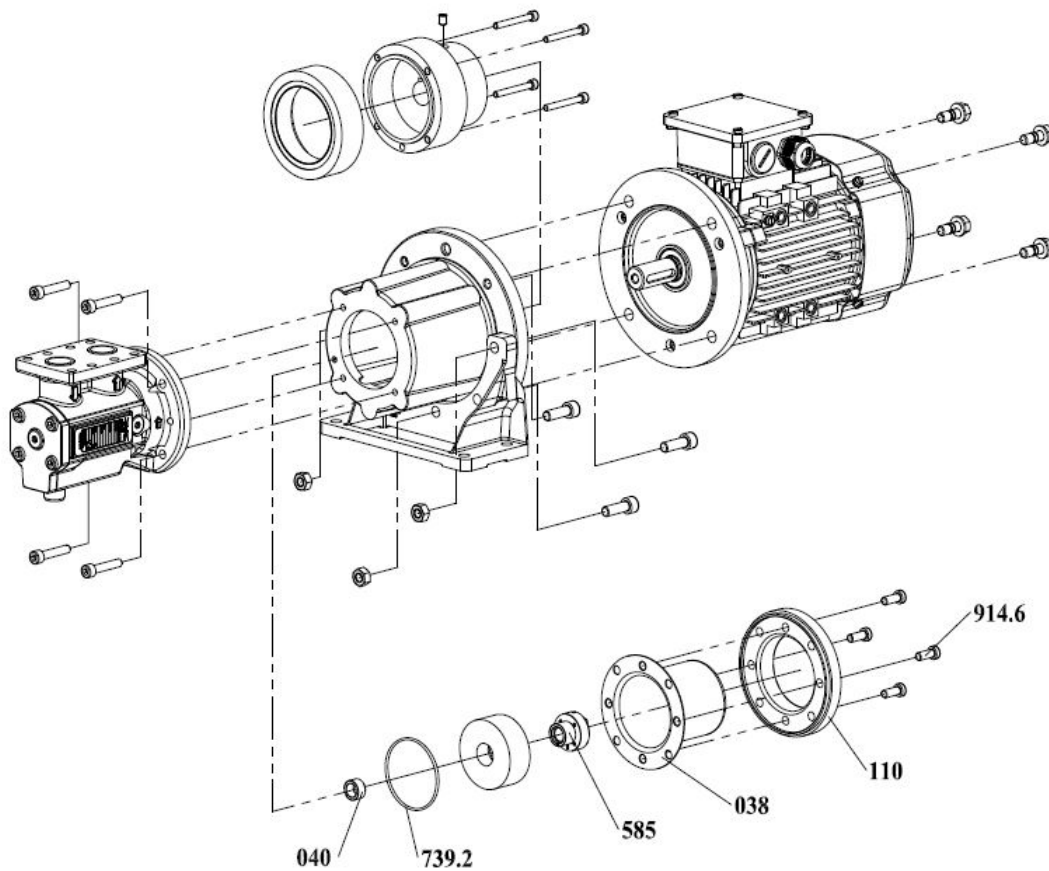

Figure 18: ALP 0015-0085: spare parts general drawing



12.2 ALP Magnetic coupling - Maintenance kit

12.2.1 ALP 0015-0020 Magnetic coupling - Maintenance kit

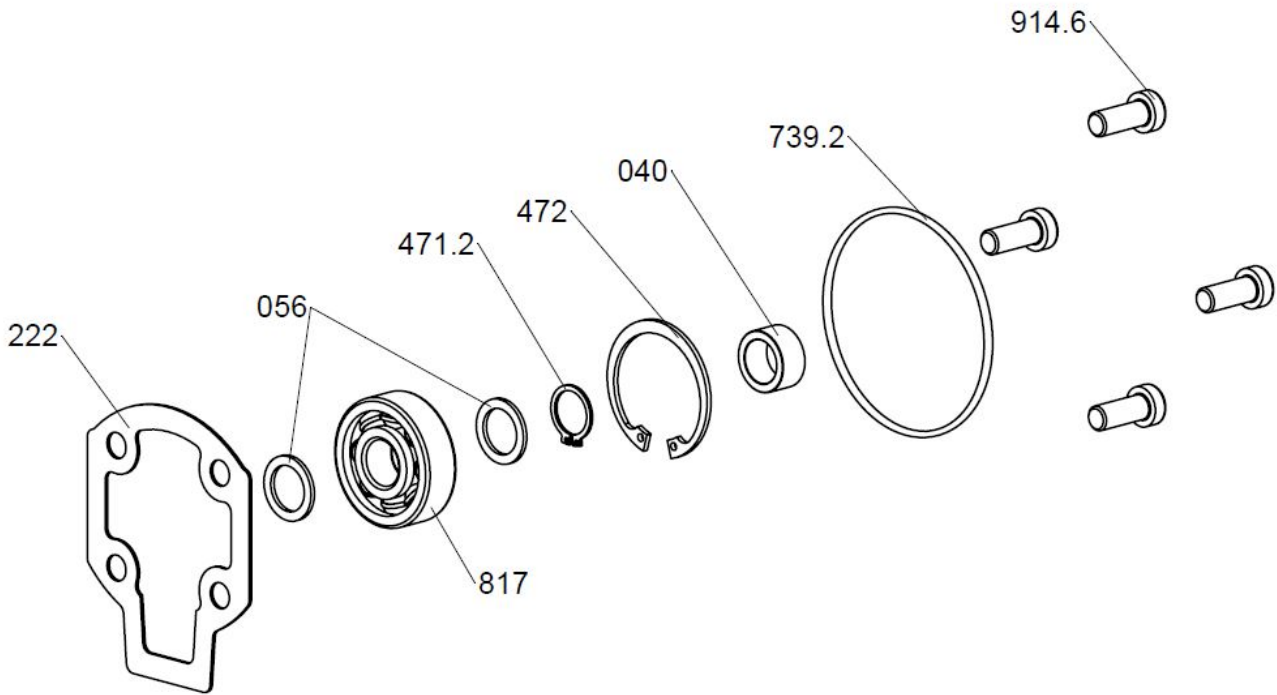

Figure 19: ALP 0015-0020 Magnetic coupling – Maintenance kit 9014380 80

Table 17: ALP-0015-0020, Magnetic coupling, Size 75, Nm 10, IEC 80+90

ALP 0015-0020 Magnetic coupling			
Denomination	Qty.	Dimensions	Pos. no.
Maintenance kit MAG 9014380 80	1		
Distance sleeve	1	D 14.2xD 20.0x10.0lg	040
Supporting ring	2	S 15x21x1.5	056
Flat gasket	1	SIL C 4400	222
Circlip	1	15x1.00	471.2
Circlip	1	42x1.75	472
O-ring	1	68.00x2.50	739.2
Ball bearing	1	6302, 15x42x13 C4	817
Socket screw	4	M 8x20	914.6
Disassembling tool	1	Refer to <i>Required tool for maintenance work</i> on page 78.	

12.2.2 ALP 0030-0040 Magnetic coupling - Maintenance kit

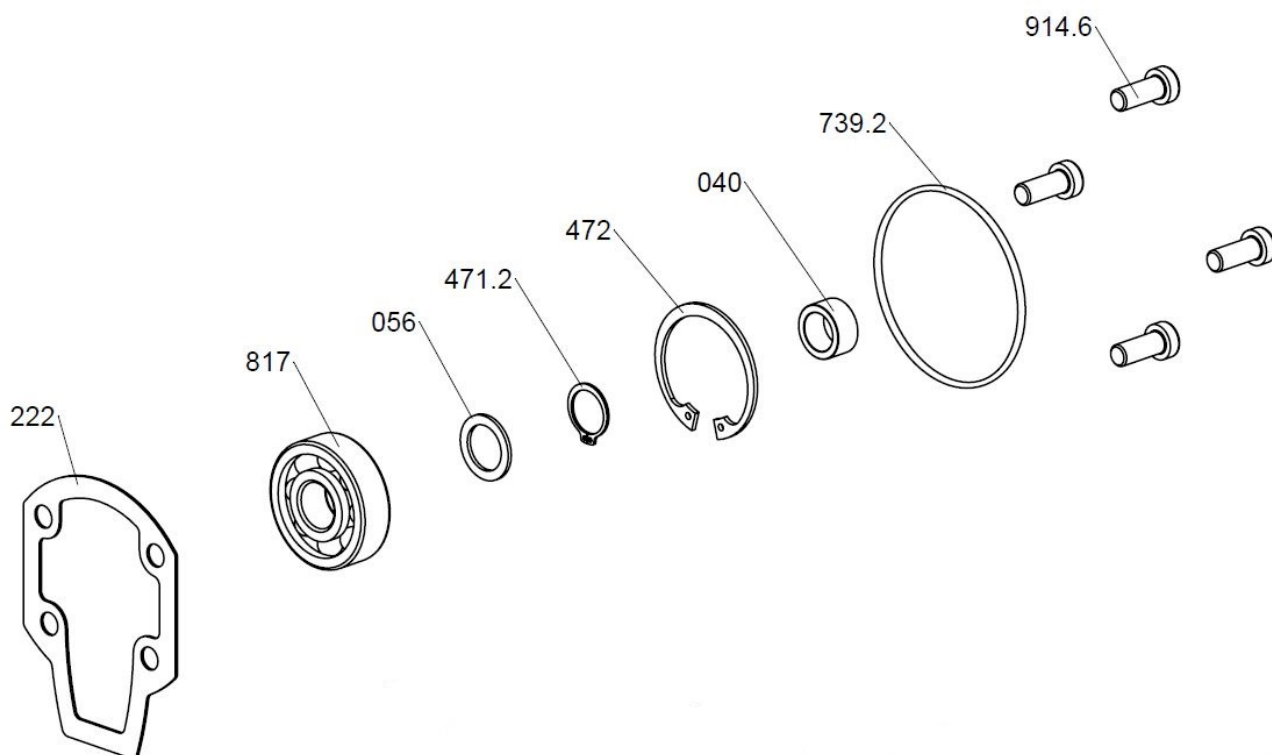

Figure 20: ALP 0030-0040 Magnetic coupling – Maintenance kit 9014380 81

Table 18: ALP-0030-0040, Magnetic coupling, Size 75, Nm 10, IEC 80+90

ALP 0030-0040 Magnetic coupling			
Denomination	Qty.	Dimensions	Pos. no.
Maintenance kit MAG 9014380 81	1		
Distance sleeve	1	D 14.2xD 20.0x10.0lg	040
Supporting ring	1	S 17x24x1.5	056
Flat gasket	1	SIL C 4400	222
Circlip	1	17x1.00	471.2
Circlip	1	47x1.75	472
O-ring	1	68.00x2.50	739.2
Ball bearing	1	6303, 17x47x14 C4	817
Socket screw	4	M 8x20	914.6
Disassembling tool	1	Refer to <i>Required tool for maintenance work</i> on page 78.	

12.2.3 ALP 0055-0085 Magnetic coupling - Maintenance kit

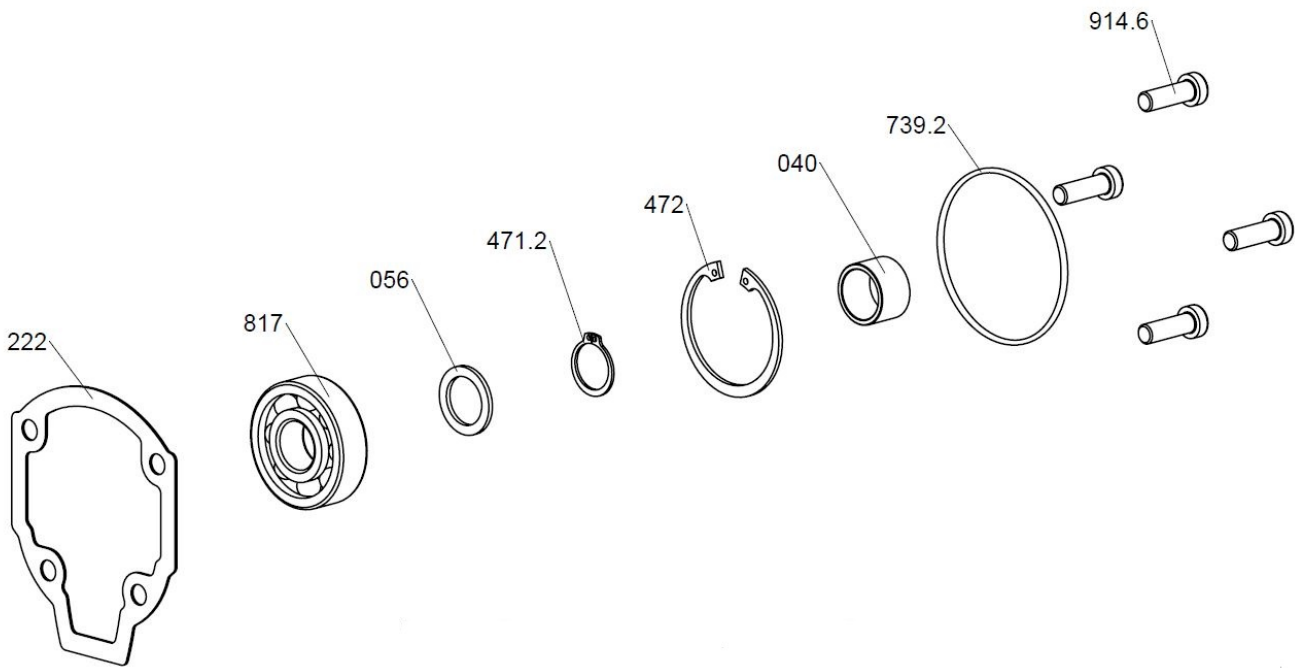

Figure 21: ALP 0055-0085 Magnetic coupling – Maintenance kit 9014380 82

Table 19: ALP-0055-0085, Magnetic coupling, Size 75, Nm 20, IEC 100/112

ALP 0055-0085 Magnetic coupling			
Denomination	Qty.	Dimensions	Pos. no.
Maintenance kit MAG 9014380 82	1		
Distance sleeve	1	D 20.5xD 25.0x16.0lg	040
Supporting ring	1	S 20x28x2.0	056
Flat gasket	1	SIL C 4400	222
Circlip	1	20x1.20	471.2
Circlip	1	52x2.00	472
O-ring	1	68.00x2.50	739.2
Ball bearing	1	6304, 20x52x15 C4	817
Socket screw	4	M 8x25	914.6
Disassembling tool	1	Refer to <i>Required tool for maintenance work</i> on page 78.	

12.3 Flange gasket

Description	Part no.
Flange gasket, D:40mm	1764628 01
Flange gasket, D:25mm	1764629 01

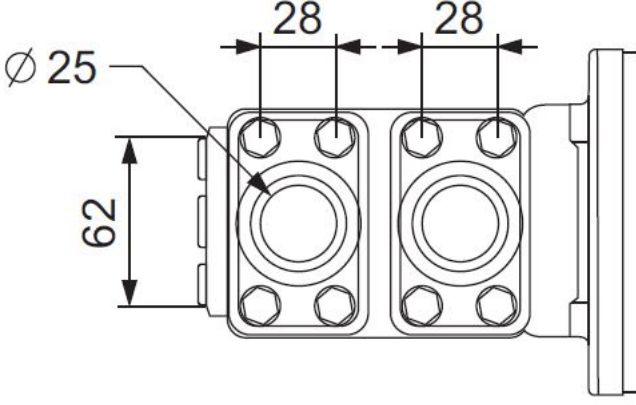
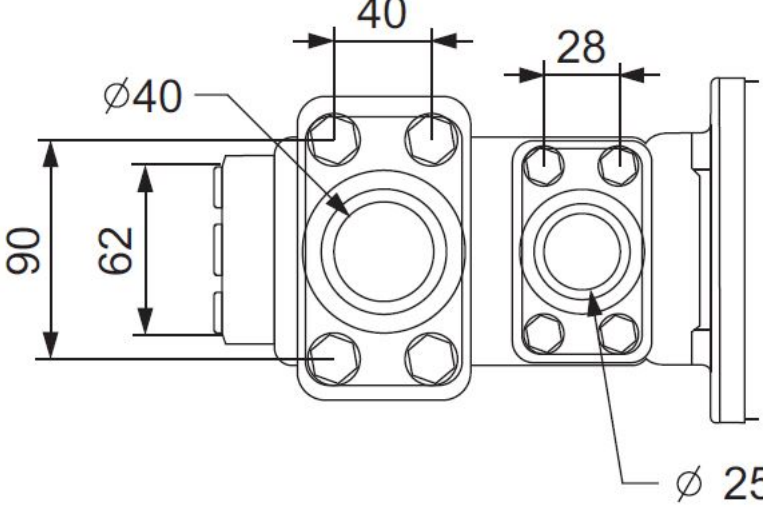
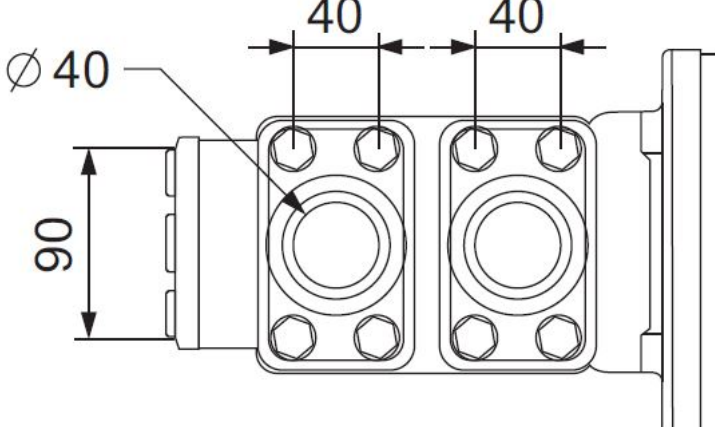
	<p>ALP 0015, ALP 0020 2x 1764629-01 D: 25 mm</p>
	<p>ALP 0030, ALP 0040 1x 1764629-01 D: 25 mm 1x 1764628-01 D: 40 mm</p>
	<p>ALP 0050, ALP 0075, ALP 0085 2x 1764628-01 D: 40 mm</p>

12.4 Tensioning element

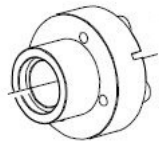
Tensioning element, Pos. 585			
	Pump type	Part no.	Qty
	ALP 0015–0020, ALP 0030–0040 Magnetic coupling,	901287601	1
	ALP 0055–0085, Magnetic coupling	901287602	1

12.5 Valve body (cone)

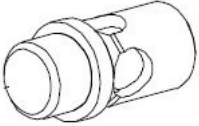
Valve body (cone), Pos. 305			
	Pump type	Part no.	Qty
	ALP 0015-0020, Magnetic coupling	901287701	1
	ALP 0030-0040, ALP 0055-0085, Magnetic coupling	901287702	1

12.6 Cylindrical spring

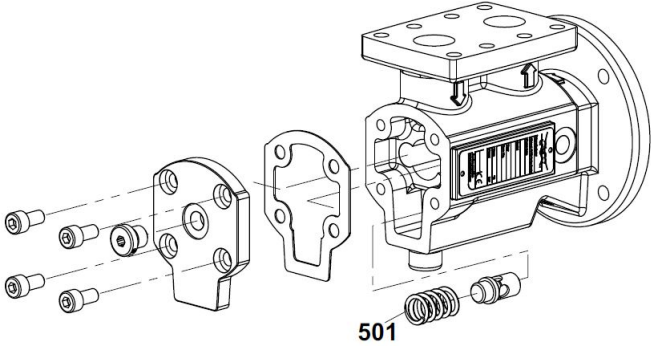
Cylindrical spring, Pos. 501			
	Pump type	Part no.	Qty
	ALP 0015-0020, Magnetic coupling	9014370 02	1
	ALP 0030-0085, Magnetic coupling	9014370 04	1

12.7 Containment can

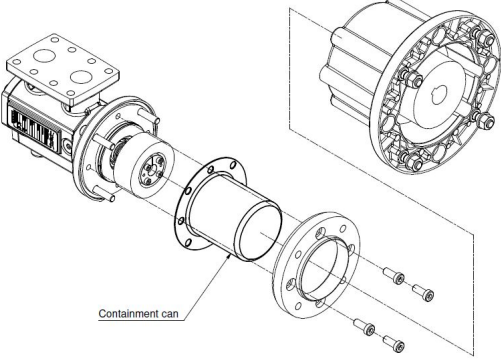
Containment can, Pos. 038			
	Pump type	Part no.	Qty
	ALP 0015-0020, ALP 0030-0040 Magnetic coupling	904356701	1
	ALP 0055-0085, Magnetic coupling	904356702	1

12.8 Screw plug for ALP magnetic coupling



Figure 22: Srew plug

Table 20: Screw plug for ALP magnetic coupling

Pump type ALP MAG	Screw plug	Part no.	Pos. no.
0015	DVV 36	9046911 01	165.1
0020	DVV 36	9046911 02	165.2
0030	DVV 36	9046911 01	165.1
0040	DVV 36	9046911 02	165.2
0055	DVV 36	9046911 01	165.1
0075	DVV 36	9046911 02	165.2
0085	DVV 36	9046911 02	165.2

13 Appendix

13.1 General drawings

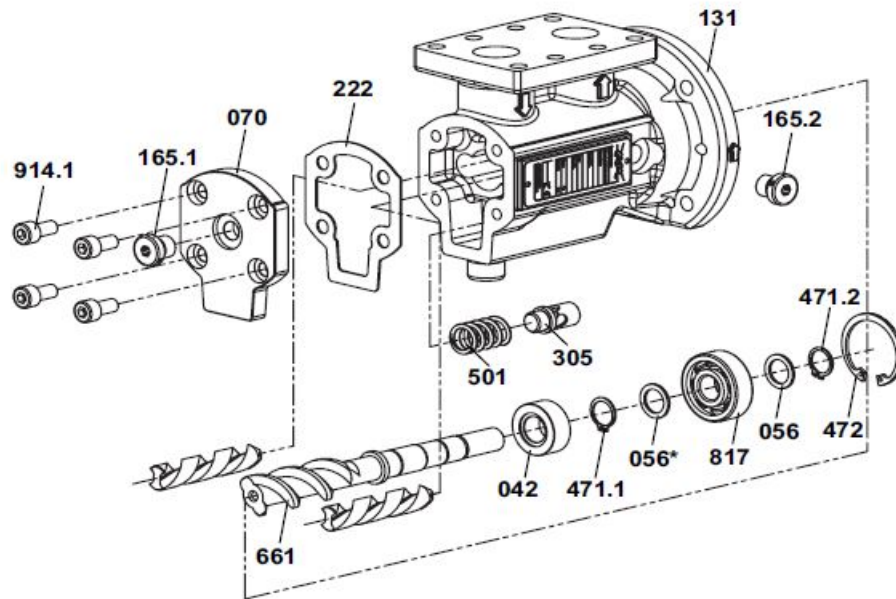

Figure 23: ALP 0015-0085

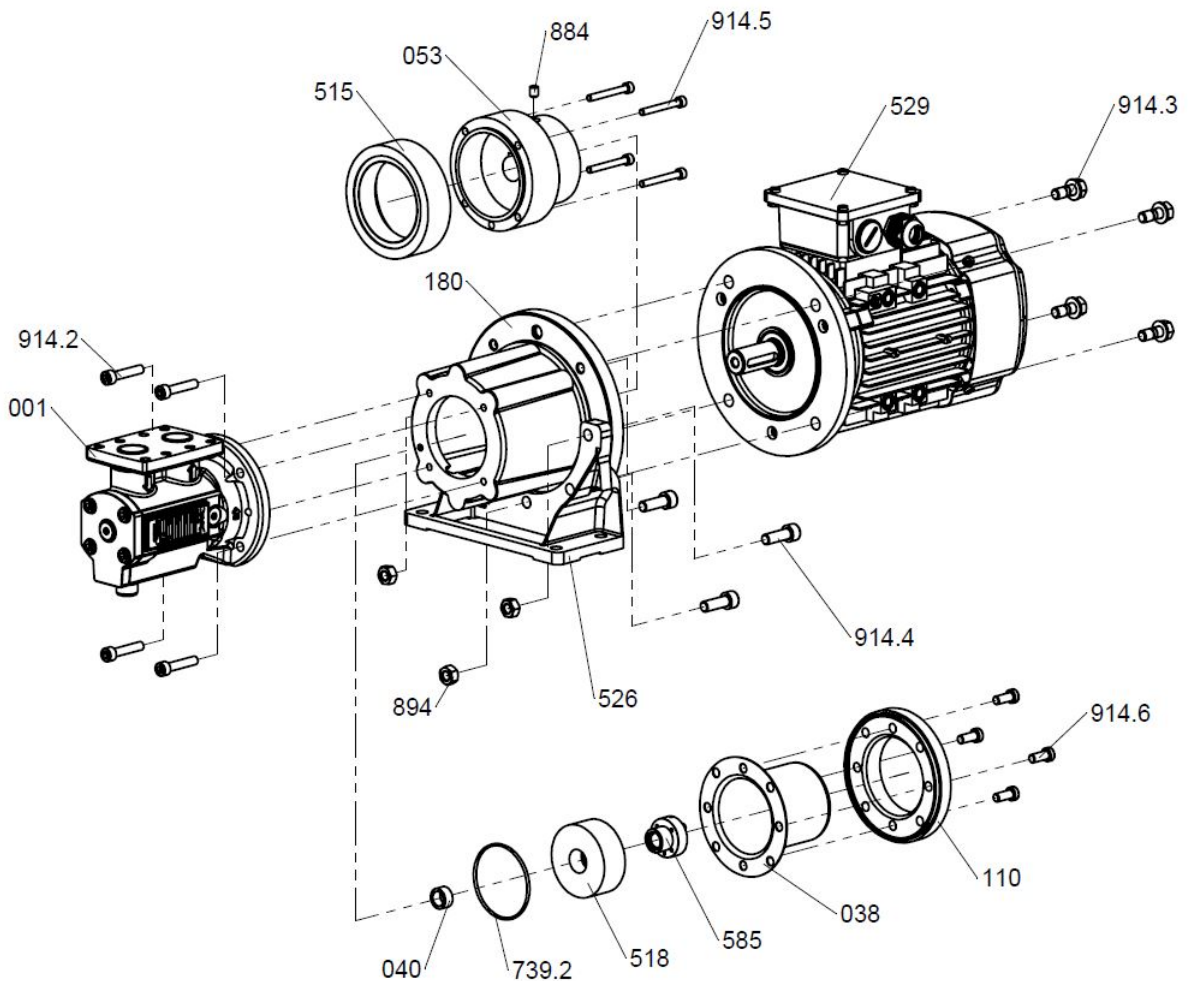

Figure 24: Completion magnetic coupling ALP 0015-0085

13.2 Parts table

Table 21: Parts numbers

Pos. no.	Denomination	Note
001	Pump	
038	Containment can	
040	Distance sleeve	
042	Balancing cylinder	
053	Coupling hub	
056 (*)	Supporting ring	* Only for sizes 15 – 20.
070	End cover	
131	Pump housing	
165.1	Screw plug	
165.2	Screw plug	
180	Pump bracket	
222	Flat gasket	
305	Valve body	
471.1	Circlip	
471.2	Circlip	
472	Circlip	
501	Spring	
515	Outer rotor	
518	Inner rotor	
526	Pump bracket foot	
529	Motor	
585	Tensioning element	
661**	Screw set	** In case of wear of the screw set we recommend to replace the pump.
739.2	O-ring	
817	Ball bearing	
884	Threaded pin	
894	Hexagon nut	
914.1	Socket screw	
914.2	Socket screw	
914.3	Socket screw	
914.4	Socket screw	
914.5	Socket screw	
914.6	Socket screw	

13.3 Tightening torques

Table 22: Tightening torques

Tightening torque [Nm] for screws with metric threads + head contact surfaces								with thread measured in inches	
Thread	8.8	10.9	8.8 + Alu*	+ wedge lock washers		Stainless steel screws A2 and A4		Screw plugs with elastomer seal	
				8.8	Rust-proof A4-70	Property class 70	Property class 80	Thread	Galvanized + stainless steel
M 3	1.5	-	1.2	1.5	1.1	-	-	G 1/8"	13
M 4	2.9	4.1	2.3	3	2	-	-	G 1/4"	30
M 5	6.0	8.0	4.8	6.0	3.9	4.7	4.7	G 3/8"	60
M 6	9.5	14	7.6	10.3	6.9	8	8	G 1/2"	80
M 8	23.1	34	18.4	25	17	22	22	G 3/4"	120
M 10	46	68	36.8	47	33	43	43	G 1"	200
M 12	80	117	64	84	56	75	75	G 1 1/4"	400
M 14	127	186	101	133	89	-	-	G 1 1/2"	450
M 16	194	285	155	204	136	135	180		
M 18	280	390	224	284	191	-	-		
M 20	392	558	313	399	267	280	370		
M 24	675	960	540	687	460	455	605		

* Reduced tightening torque when screwing into aluminium.

Table 23: Tightening torques for fixing screws of conical hub connectors

Tightening torques [Nm] for fixing screws of conical hub connectors	
Thread	12.9
M 3	1.8
M 4	4.5
M 6	16
M 8	37
M 10	73
M 12	126

13.4 Required tool for maintenance work

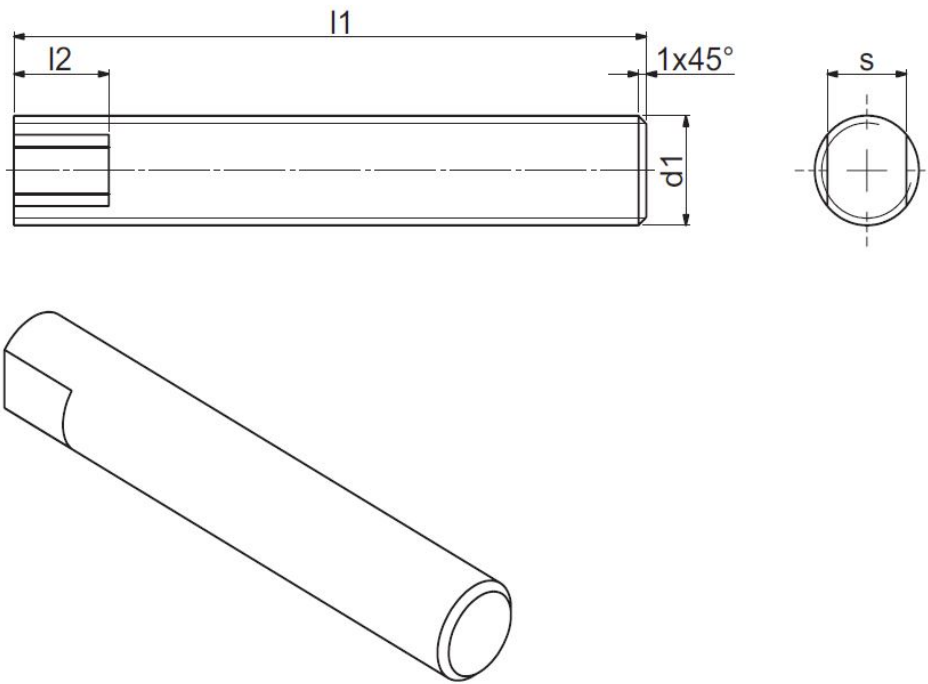

Figure 25: Disassembly tool

Table 24: Disassembly tool dimensions

Disassembly tool dimensions [mm]				
Size	d1	l1	l2	s
15 – 85	G 1/4"	80	12	10

14 EC Declaration of conformity

EC Declaration of conformity

12 Appendix

EC Declaration of conformity



The designating company

Alfa Laval Kolding A/S

Company name

Albuen 31, DK-6000 Kolding, Denmark

Address

+45 79 32 22 00

Phone No.

hereby declares that

Denomination: Three-Screw Pump
 Type: ALP
 Date: 2013-04-01

Is in conformity with

- Machinery Directive 2006/42/EC

and furthermore declares that if motorised the following applicable directives have been used

- Directive 2006/95/EC on low voltage
- EMC Directive 2004/108/EC

The technical construction file for this machinery has been drawn up. The signer of this declaration is authorized to compile the technical file.

Manager, Product Center Fluid Handling

Title

Bjarne Søndergaard

Name

A handwritten signature in black ink, appearing to read 'B. Søndergaard'.

Alfa Laval Kolding A/S

Company

Signature