



KRAL Screw Pumps.

Hermetically sealed pumps with magnetic coupling for PUR.

■■■■■■■ Pumps

KRAL Screw Pumps for PUR Manufacture.

Fillers in PUR are making matters more critical. KRAL responds with innovations.

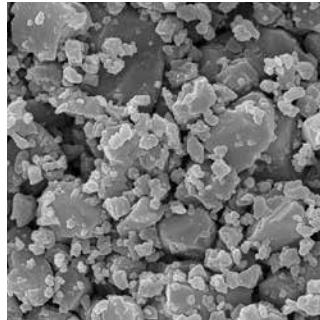

Operation and materials.

| | |
|--------------------|---|
| Flow rate*: | Up to 800 l/min. |
| Max. pressure: | 100 bar. |
| Temperature range: | -40 °C to 300 °C. |
| Viscosity: | Up to 5,000 mm ² /s. |
| Casing: | Spherulitic graphite iron and steel. |
| Spindles: | Nitride steel. |
| Magnetic material: | Sm ₂ Co ₁₇ permanent magnets. |
| Energy density: | 250 kJ/m ³ . |

*Higher flow rates on request.
Technical data subject to the pump series.

Install and forget.

Polyol is highly viscous at low temperatures. During a cold start-up, high torque is applied to the rotating parts. The mechanical seal, which comes under an extreme load, is particularly affected.

The spring of the mechanical seal can slip on the shaft. This can cause the spring to disengage and even break. A spring that is disengaged can damage the rotating face to the point of breaking. A mechanical seal damaged in this way can cause massive pump leakage.

The only lasting remedy is to do away with the mechanical seal. KRAL pumps with magnetic coupling replace the mechanical seal. Where previously the mechanical seals had to be replaced up to three times a year, we now have a "carefree" situation. You simply install and forget!

Avoid damage from fillers.

Fillers are abrasive. Fillers are increasingly being added to polyurethane. Fillers increase the abrasive properties of the PUR, for grinding tools and terrace slabs, for example. Other fillers reduce flammability or improve electrical insulation properties. Abrasive fillers wear out the mechanical seal, the spindles and the casing of the pump.

The magnetic coupling replaces the mechanical seal, so it is no longer possible to damage the mechanical seal. The concept behind KRAL magnetic coupling pumps enables them, on consultation with KRAL, to be designed for numerous fillers by using hardened spindles and pump casings.



The screw pump has a clear advantage.

Due to its lower price, a gear pump could also be considered.

Beware! The disadvantage with gear pumps is that the liquid is exposed to high shear forces and crushing at the gear wheels as they intermesh. This damages the polymer chains, which is why gear pumps are operated at low speeds.

KRAL screw pumps are gentle on the media they deliver at high speeds. This ensures that the power density is efficiently high.

KRAL – your reliable partner.

Constructors of PUR plants can only successfully handle time-critical projects if the schedule is well coordinated and agreed in close collaboration with the pump supplier.

KRAL is continually proving to be a highly efficient, flexible and reliable partner. When there are special requirements, KRAL develops customized special solutions together with the customer.



Photo: Krauss-Maffei Kunststofftechnik GmbH.

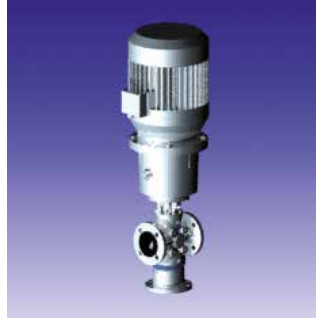

Prevent blistering.

Water and air cause blisters in the end product. Especially with transparent systems, this is immediately obvious and can lead to complaints.

To prevent air being drawn into the PUR processing machine, the machine is set up in a vacuum. KRAL screw pumps are self-priming. Even under these conditions, they have no trouble working at about -0.5 bar. However, a mechanical seal is not vacuum tight. Air can be drawn in through the unsuitable seal.

The magnetic coupling also provides the remedy here. The sealing element of the magnetic coupling is the containment can. The containment can provides a totally hermetic seal against the vacuum.

Prevent reactions in the pump.

Each mechanical seal has a stationary and a rotating sealing face. The sealing faces are lubricated by the pump medium. The liquid is in contact with air at the sealing faces. This can cause problems.

Isocyanate reacts with water and forms urea. The abrasive urea crystals damage the surfaces of the mechanical seal, resulting in leakage. The crystals also prevent the axial displacement of the sliding ring and damage the O-ring. This also results in leakage. Depending on the isocyanate, the mechanical seal may have to be replaced several times a year.

As the magnetic coupling is hermetically tight, the polyol and the isocyanate do not come in contact with the outside air.

Vertical operating position possible.

If the polyol or the isocyanate can collect somewhere in the pump, they may set, which would limit pump functionality.

KRAL screw pumps with magnetic coupling are designed in such a way that there are no dead spaces. Liquids cannot stay in one place for a long time. During filling and commissioning, the pump is automatically self-venting. This means that it can also operate in the vertical position allowing for a more compact PUR processing machine design.

KRAL – the specialist for the PUR industry.

KRAL has a variety of solutions to offer to polymer producers, mechanical engineers and component producers:

- Magnetically coupled pumps as transfer pumps for the raw materials of PUR.
- Pumps with a mechanical seal for supplying the raw materials for the production machines from the polyurethane tank depot.
- Magnetically coupled pumps and mechanical seal pumps for PUR production machines.
- Unloading pumps. Statutory provisions prescribe that unloading must take place from the top. KRAL screw pumps can do this, because they are self-priming.

■■■■■■■■ Pumps

Innovative Solutions and Ultimate Quality.

The “carefree” pump for polyurethane.

■ The “carefree” situation.

A lasting solution to the problem of frequently replacing mechanical seals is to use the magnetic coupling pump with a spherulitic graphite iron casing for polyol and isocyanate.

■ Areas of application.

Whether as unloading pumps or transfer pumps for the raw materials of PUR, for supplying the production machines with raw materials or as feed pumps directly to the PUR production machines, KRAL is always first choice.

■ No more faulty seals.

The high torque produced by a cold start-up can damage mechanical seals. This is no longer possible with magnetic coupling. With mechanical seals, the sealing faces and the O-ring can be damaged by urea crystals. The magnetic coupling is completely airtight and prevents the crystals forming.

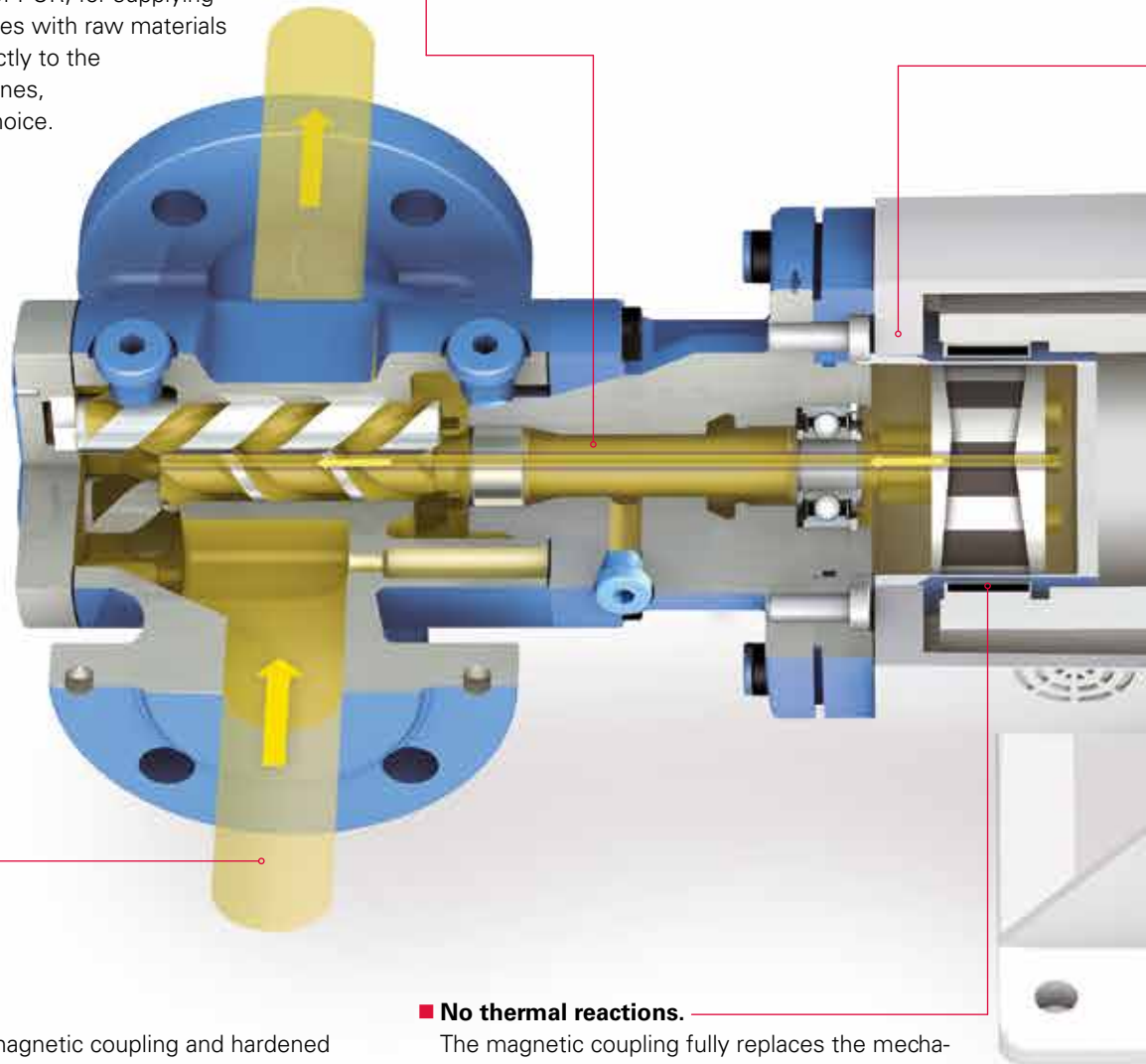

■ Polyol with fillers.

On consultation, the magnetic coupling and hardened spindles and pump casings can make KRAL pumps suitable for some of the fillers in polyol.

■ No thermal reactions.

The magnetic coupling fully replaces the mechanical seal. As there are no longer any sealing faces to rub, the thermal reactions of the isocyanate in the pump is considerably reduced.

■ **No blistering.**

When the PUR processing machine is set up in a vacuum, the hermetically sealed magnetic coupling prevents air from being taken in. Blistering is thus avoided.

■ **The better pump principle.**

Unlike gear pumps, screw pumps do not damage the polymer chains. Screw pumps can run at high speeds.

■ **Minimize inventory.**

If the same magnetic coupling pump with a spherulitic graphite iron casing is used for polyol and isocyanate, then you only have to keep a single series in stock. This saves you money.

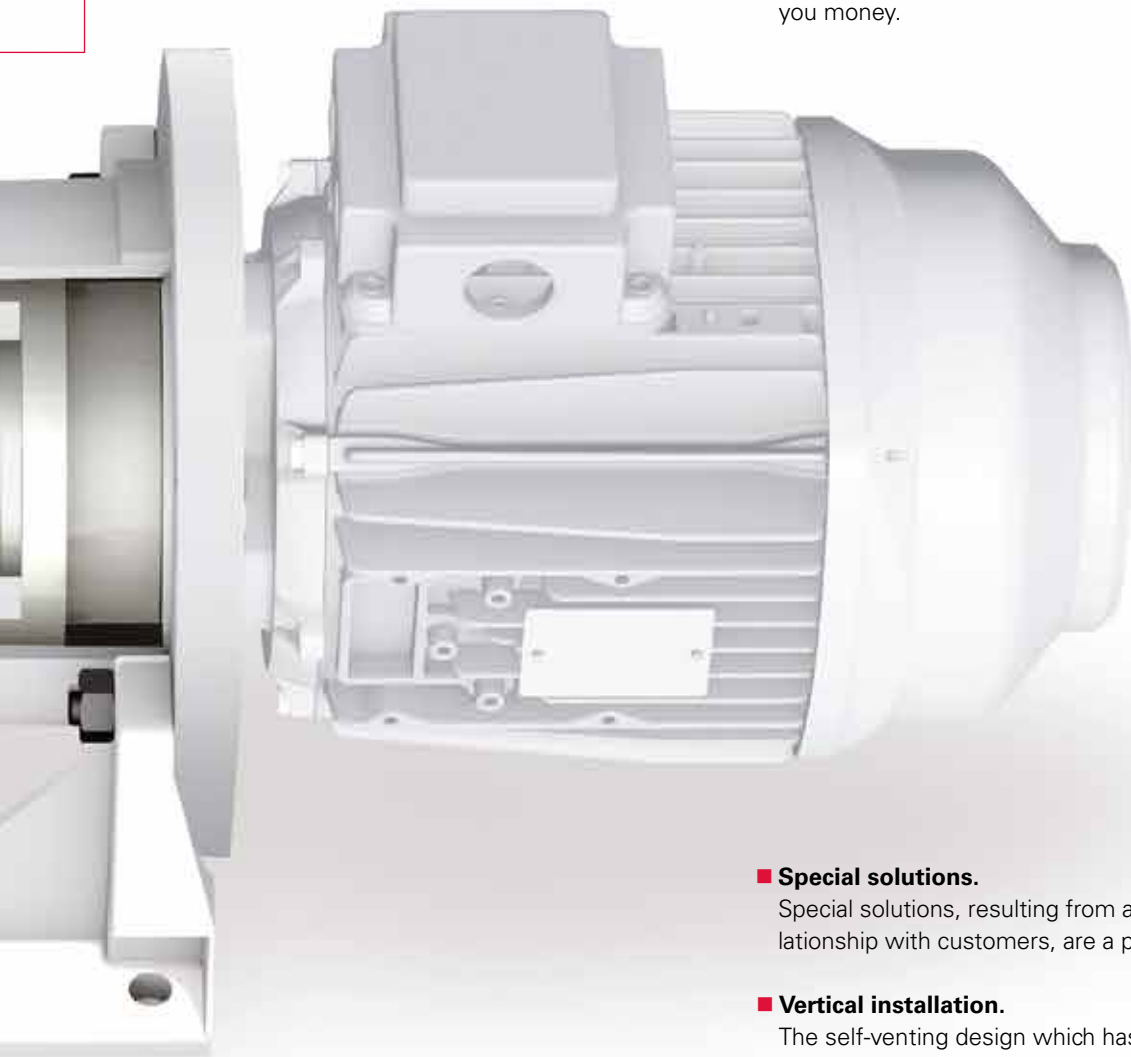

■ **Special solutions.**

Special solutions, resulting from a collaborative working relationship with customers, are a particular strength at KRAL.

■ **Vertical installation.**

The self-venting design which has no dead spaces allows the pump to be mounted vertically to save space.

■■■■■■■ Pumps

KRAL Pumps with Magnetic Coupling for Polyurethane.

Technical data.



| Technical data. | Flow rate*. | Pressure. | Temperature. |
|------------------|-------------|-----------|--------------|
| K series. | 400 l/min | 16 bar | 300 °C |
| L series. | 200 l/min | 40 bar | 300 °C |
| C series. | 800 l/min | 100 bar | 300 °C |

| Application. | Unloading pump. | Transfer pump. | Circulation pump. |
|------------------|-----------------|----------------|-------------------|
| K series. | • | • | • |
| L series. | | | • |
| C series. | • | • | |

*Higher flow rates on request.

Practical Examples.

KRAL applications.



Photo: Isotherm AG.

Piston batching plant.

Pump type: L 20.64 with magnetic coupling.
 Pressure: Approx. 12 bar.
 Viscosity: 2,000 mPa·s polyol.
 Isocyanat 500 mPa·s.

Polyol and isocyanate are mixed and heated in pressure tanks. During recirculation, the magnetically coupled screw pumps pump the components gently and evenly through the heated filters, batching pumps and PTFE hoses to the mixer head and back to the tanks. This allows a constant mixer head temperature and component viscosity to be maintained. Pressing the shot firing trigger stops recirculation and switches the batching pumps to high pressure. The mixer head opens and the molten mixture emerges. At the end of the shot, the remaining mixture is automatically ejected from the mixing chamber.



Photo: Isotherm AG.

Batching plant for filter adhesives.

Pump type: L 20.78 with magnetic coupling.
 Resistant to fillers.
 Pressure: Approx. 20 bar.
 Viscosity: 15,000 mPa·s polyol. Extended with 60% powdered chalk.

Polyurethane filter adhesives are extended up to 60% with abrasive fillers. These act like abrasive paste in the screw pumps. So for situations like this, a special abrasion-resistant magnetically coupled pump is used. The speed is also reduced by a frequency converter to the absolute minimum necessary. Reducing the pump speed to 200 min⁻¹ can extend the life to 7,000 hrs.



Photo: Krauss-Maffei Kunststofftechnik GmbH.

Plant constructor.

13 pumps CGJV 15 with magnetic coupling.
 Pressure: Approx. 20 bar.
 Viscosity:
 1,000 mm²/s isocyanate.
 3,000 mm²/s polyol.

Different polyols and isocyanates are stored in tank depots. Tank depots are used to supply the raw materials to the production plants. The feeding tanks are fitted with protection against dry-running for the screw pumps.

Raw materials are delivered from the large feeding tanks to the smaller working tanks. From there, transfer pumps are used to pump the raw materials to the production plants. Pipelines can be up to 300 m long. Hermetically sealed KRAL screw pumps with magnetic coupling are used to prevent the highly-viscous polyol and the hygroscopic isocyanate coming into contact with the air or with other particles.



Photo: Krauss-Maffei Kunststofftechnik GmbH.

Component producer.

Pump type: KF 118.DCA.
 Flow rate: 20 to 110 l/min.
 Pressure: Up to 15 bar.
 Temperature: Up to 190 °C.
 Viscosity: 300 to 5,000 mm²/s.

Mattresses and car seats are made from flexible PUR foams, refrigerator insulation and façade elements from rigid PUR foam. The preparation and precise batching of the liquid components are crucial criteria for component quality and process stability. In special applications, the polyol components can be highly viscous.

KRAL screw pumps work very precisely and reliably. For end-product customers, this means outstanding product quality and high plant availability, even if the materials used are highly viscous.

